



**POLARIS**<sup>®</sup>

INTERNATIONAL VERSION



**APPAREL & ACCESSORIES**  
POLARISSVERIGE.COM

**2020**





## RMK®

LIGHTEST. STRONGEST.  
MOST FLICKABLE.



## SWITCHBACK®

SMOOTHEST RIDING.  
MOST VERSATILE.



## POLARIS TITAN®

UNMATCHED CAPABILITY.  
UNCOMPROMISING PERFORMANCE.

## KNOW YOUR CHASSIS FOR THE PERFECT FIT

Depending on the model of snowmobile you have and its model year, you may have either a Pro-Ride® chassis or an AXYS® chassis. Please consult the chart below to determine which chassis you have and order accordingly.

	PRO-RMK®, SKS	RMK® KHAOS	RMK® EVO	RMK® Assault®	Switchback® Assault® 144 & RMK® 144	Switchback®	Switchback® SP	RUSH®
AXYS®	MY16-MY20	MY20	—	MY16-MY19	MY17-MY20	MY15-MY20	MY17-MY20	MY15-MY20
PRO-RIDE®	MY11-MY15	—	MY20	MY11-MY15	MY11-MY16	MY10-MY14	—	MY10-MY14



# 2020

## APPAREL & ACCESSORIES



**INDY®**

LEGENDARY PERFORMANCE.  
SIMPLY FUN.

**VOYAGEUR®**

LIMITLESS  
POSSIBILITIES.

### APPAREL

- MEN'S RIDING GEAR **8**
- WOMEN'S RIDING GEAR **12**
- YOUTH RIDING GEAR **14**
- LAYERING **16**
- HELMETS **18**
- GOGGLES **22**
- GLOVES **24**
- BOOTS **26**
- BEANIES **27**
- MEN'S LIFESTYLE **28**
- WOMEN'S LIFESTYLE **30**
- HATS **31**
- OGIO® BAGS **32**

### ACCESSORIES

- POLARIS ENGINEERED™ **42**
- STORAGE & RACKS **44**
- STORAGE, CARBIDES & HITCHES **50**
- SEATING **54**
- BUMPERS **56**
- WINDSHIELDS **58**
- RUNNING BOARDS & SKID PLATES **60**
- RIDE COMMAND® & P.I.D.D. **62**
- HOOD PANELS & WRAPS **63**
- HANDLEBARS & ELECTRONICS **64**
- COVERS & TRAILERING **66**
- SKIS, SHOCKS & KITS **68**
- TRACKS **70**

### GARAGE

- KEY COMMODITIES & BELTS **72**
- OIL **74**
- LUBRICANTS & PORTABLE POWER **76**
- LIFTS & BATTERIES **78**
- SERVICE PARTS **79**

TITAN®	600 INDY®	600 Voyageur®	550 INDY® 121 / 144	550 Voyageur®	550 INDY® LXT, INDY® Adventure	INDY® XC 129	INDY EVO™	INDY® Adventure 137, INDY® XC 137	INDY® XCR
MY18-MY20	—	MY17-MY20	—	—	—	MY19-MY20	—	MY20	MY20
—	MY13-MY20	MY14-MY16	MY13-MY20	MY13-MY20	MY13-MY20	—	MY19-MY20	—	—



**POLARIS®**

ENGINEERED APPAREL

# RIDING GEAR BORN OF A HIGHER STANDARD.

**INTRODUCING OUR MOST ADVANCED RIDING GEAR EVER!**

It represents years of experience as riders and technical developers that was infused into making an all new lineup of high-performance technical outerwear. Advanced material science is applied to deliver riding gear that will improve your ride. Through our rigorous design and testing process, TECH54™ was born—a new, high-performance membrane featured inside every jacket and bib that offers more waterproof breathability than any other construction and material combination we've developed to date.



## DESIGNED

Modern riders demand stylish gear that's fit for the ride and performs in ever-changing elements. Our product designers skillfully use the best components and materials to develop riding gear that performs to your highest standards.



## PROVEN

Polaris Engineered Apparel™ is proven in our advanced development lab and thoroughly tested by the hardest-riding people on the trails and in the backcountry—our team of expert riders, engineers and pro riders.





### SUPERIOR DWR COATING

Superior Durable Water Repellency (DWR) prevents precipitation from saturating the exterior of all outerwear pieces.

### TECH54™ WATERPROOF BREATHABLE

A waterproof and breathable membrane is bonded to the shell fabric to block moisture from entering while allowing vapor moisture to escape from the inside—keeping you dry in both directions.

## INTRODUCING

# TECH54™

## BORN FROM EXPERIENCE.

Since 1954, Polaris® has been at the forefront of developing newer, better snowmobile technology. As sleds become lighter and faster, and we as consumers become more technical, our apparel must evolve to exceed the demands of today's riders and perform better than ever before. That's why we designed TECH54™. Born in our technical Center of Excellence, engineers and riders worked in close collaboration to prototype, test and develop a material that would be comfortable, waterproof and breathable to meet the unique demands of every rider. The result is apparel that delivers everything riders need and nothing that they don't.

## HOW IT WORKS TO ELEVATE YOUR RIDE.

### 5k/5k OR 10k/10k

#### WATERPROOF

The first number (5k or 10k) refers to the waterproof rating.

#### BREATHABILITY

The second number (5k or 10k) refers to how much water vapor the material can expel through the jacket to release heat—and keep you dry from the inside.

#### DIFFERENT RATINGS FOR DIFFERENT RIDES

Products with a TECH54™ 10k/10k rating are designed for our most active riders, while riding gear with a TECH54™ 5k/5k rating is ideal for less active riding. Make your choice based on how hard you exert yourself while riding, or the type of riding you most consistently do.

**TECH54™ IS FEATURED IN EVERY POLARIS® JACKET & BIB.**

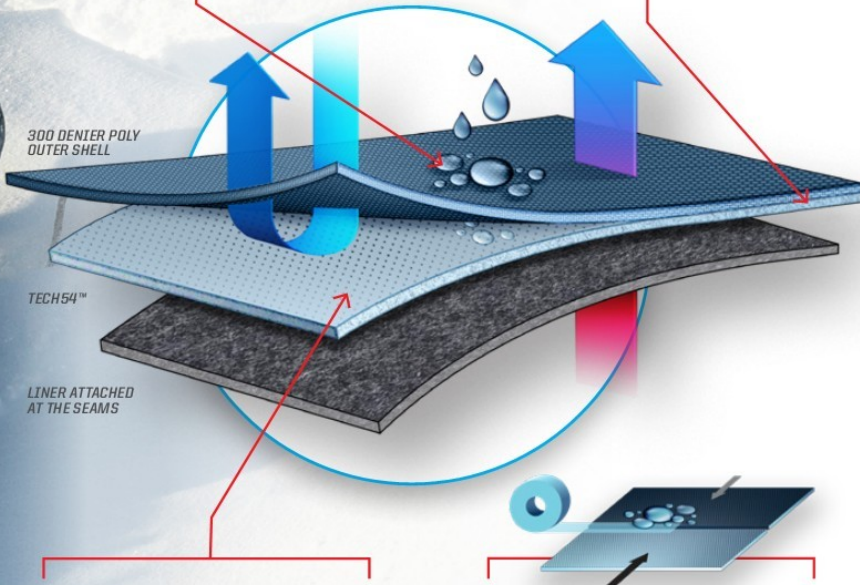

### 5k/5k 10k/10k RATING

Different levels of waterproof breathability tailored for different riding styles.

### CRITICALLY TAPED SEAMS

Internally taped seams fully block precipitation while retaining breathability.

## TRUSTED

Nobody knows the ride like us. The result of our collaborative design process is a Polaris Engineered™ advantage that lives inside every piece of riding technical gear and accessory we make. Because trust is earned on the snow, where we are at our best.

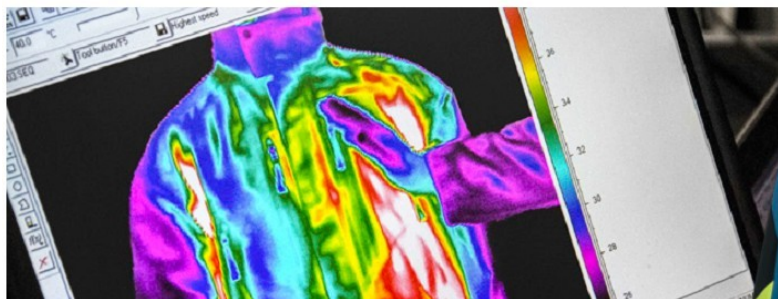



# OUR MOST EVOLVED RIDING APPAREL EVER.

As riders and snowmobile experts, we know the difference quality apparel makes while riding. Our apparel features the best combination of class-leading technologies that have been continuously tested and refined. Keeping you dry, warm and comfortable in every riding condition is our quality promise to every rider wearing the Polaris® name.

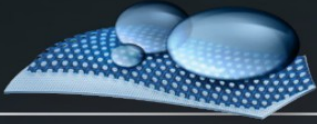

**DWR**

## RESIST MOISTURE

Every Polaris® jacket and bib is treated with a superior-rated DWR (Durable Water Repellent) coating to prevent precipitation from saturating the outer fabric, so your gear doesn't get soggy. The DWR coating causes water to bead up and run off, keeping you comfortable and dry.

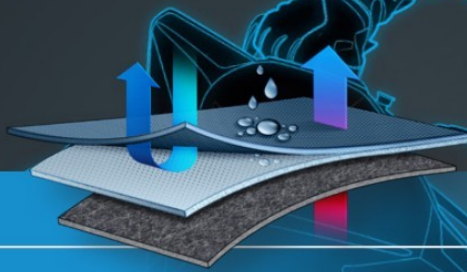

**TECH54**

## WATERPROOF/BREATHABLE

TECH54™ is our single-layer bonded laminate technology that brings waterproof breathability and riding comfort to a new level in every Polaris® jacket and bib.

**YKK®  
ZIPPERS**

## LAST LONGER

The most trusted name in the industry. Quality construction that doesn't fail.

**509 FOR  
POLARIS®**

## SUPERIOR PROTECTION

A trusted name in helmet and goggle manufacturing, 509® helmets utilize advanced materials like carbon fiber for lightweight protection.

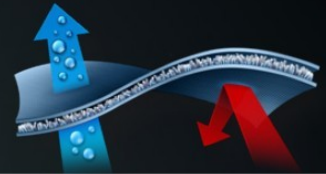

**3M  
Thinsulate®  
INSULATION**

## BE WARMER

3M® Thinsulate® Insulation is zonally mapped on insulated apparel to provide extra insulation in high wind exposure areas.

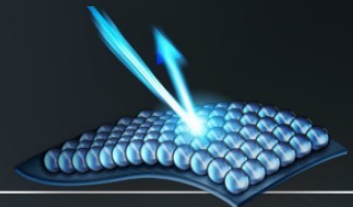

**3M Scotchlite®  
Reflective Material**

## RIDE SAFER

Proven in every weather condition, patented 3M® Scotchlite® Reflective Material is placed meticulously on each garment and nighttime tested to ensure rider safety and visibility from every angle.



# LAYERING 101

Polaris® brand outerwear is designed to work together as a smart solution that integrates multiple layers for ultimate performance. We offer a range of innovative products that are designed to deliver comfort, warmth and mobility for every riding style.

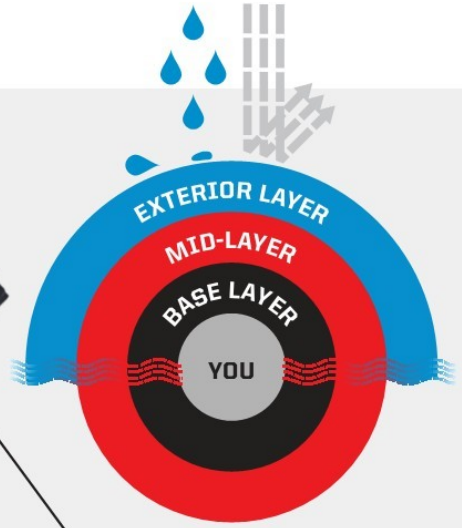

**BASE LAYER**

Rests against your skin to regulate your overall temperature by wicking away moisture. Must be light, quick-drying and quick-wicking.



**MID-LAYER**

Works to pull moisture away while keeping body heat near your skin. Usually a mid-weight layer followed by an outerwear jacket.



**EXTERIOR LAYER**

Retains inner warmth, prevents external cold from entering and regulates body temperature by venting moisture and blocking out wind, snow and water.

## SIZING GUIDE

### MEN'S JACKET & BIB SIZING

Size:	S	M	L	XL	2XL	3XL
Chest:	34-36	38-40	42-44	46-48	50-52	54-56
Sleeve*:	33-35	33-35	34-35	34-35	34-35	34-35
Waist:	31-33	35-37	39-41	43-45	47-49	51-53
Hips/Seat:	34-36	38-40	42-44	46-48	50-52	54-56
Inseam:	30-35	30-35	30-35	30-35	30-35	30-35

### WOMEN'S JACKET & BIB SIZING

Size:	S	M	L	XL	2XL	3XL
Chest:	32-34	35-38	39-42	43-46	47-50	51-54
Sleeve*:	29-30	31-33	31-33	31-33	31-33	31-33
Waist:	26-28	29-32	33-36	37-40	41-44	45-48
Hips/Seat:	35-37	38-41	42-45	46-48	50-53	54-57
Inseam:	26-29	27-30	27-30	27-30	27-30	27-30

\* Measure sleeve length from center back neck. Helmet sizing on page 16.



UNINSULATED

**TECH54**

10K/10K

**BLUE/LIME**

Sizes: S-3XL  
2860520

**LIME**

Sizes: S-3XL  
2860534

**BLACK**

Sizes: S-3XL  
2860533

**GRAY/RED**

Sizes: S-3XL  
2860519



**REVELSTOKE JACKET**



**3M Scotchlite**  
Reflective Material



**ADVANCED UNINSULATED JACKET WITH MAXIMUM BREATHABILITY AND WATERPROOFNESS**

- Durable 300 denier poly shell is tear- and snag-resistant and treated with superior DWR to shed snow and water from the outer shell
- Features TECH54™ bonded internal laminate with 10k/10k properties
- Three external pockets (two hand, one chest)
- Four vents (two front, two back)

- Shock cord adjustable bottom hem
- 3M® Scotchlite® Reflective Material for nighttime visibility

**WARMTH**

**BREATHABILITY**

**VERSATILITY**



**REVELSTOKE BIB**



**3M Scotchlite**  
Reflective Material



**ADVANCED MOUNTAIN BIB WITH MAXIMUM VENTING, COMFORT AND WATERPROOFNESS**

- Durable 300 denier poly shell is tear- and snag-resistant and treated with superior DWR to shed snow and water from the outer shell
- Features TECH54™ bonded internal laminate with 10k/10k properties
- Storm cuffs with boot lace retention snaps

- 3M® Scotchlite® Reflective Material for nighttime visibility
- Two thigh vents
- Two-way front zipper

**WARMTH**

**BREATHABILITY**

**VERSATILITY**

**ACTION BACK**  
GIVES A WIDE  
RANGE OF MOTION



# MEN'S PRO MONOSUIT **NEW**

DWR

3M Scotchlite<sup>™</sup>  
Reflective Material

YKK<sup>®</sup>  
ZIPPERS

OUR MOST EVOLVED ONE-PIECE WITH MAXIMUM BREATHABILITY, WATERPROOFNESS, INCREASED RANGE OF MOTION AND NOW WITH MORE POCKETS

- Durable 300 denier poly shell is tear- and snag-resistant and treated with superior DWR to shed snow and water from the outer shell
- Features TECH54<sup>™</sup> bonded internal laminate with 10k/10k properties
- One-piece construction ensures powder stays on the outside
- 3M<sup>®</sup> Scotchlite<sup>™</sup> Reflective Material for nighttime visibility
- Provides room for a mid-layer for added warmth against the cold
- Increased storage including four external pockets (two hand, one chest, one thigh)

WARMTH

BREATHABILITY

VERSATILITY

**TECH54**<sup>™</sup>  
10K/10K

UNINSULATED

## IMPROVED MOBILITY

Action back for ease of movement and articulated fit for maximum mobility and comfort.



## CUSTOMIZED FIT

Adjustable internal suspenders for comfort and customized fit.



## SUPERIOR VENTING

Two vents on the side and two vents on the leg help dump heat as needed when riding, and the leg zips can be opened for extra venting when off the sled.



FOR LAYERING EDUCATION SEE P. 7

BLACK/LIME

Sizes: S-3XL  
2860522

NAVY

Sizes: S-3XL  
2860523



**TECH54**

10K/10K

**BLACK/LIME**

Sizes: S-3XL  
2860515

**BLACK**

Sizes: S-3XL  
2860532

INSULATED



**RED**

Sizes: S-3XL  
2860516



**CROSSOVER**

**SWITCHBACK JACKET**

**DWR**

**3M Thinsulate**  
INSULATION

**3M Scotchlite**  
Reflective Material

**YKK**  
ZIPPERS

**PREMIUM JACKET WITH REMOVABLE INSULATED LINER FOR ALL-DAY VERSATILITY**

- Durable 300 denier poly shell is tear- and snag-resistant and treated with superior DWR to shed snow and water from the outer shell
- Features TECH54™ bonded internal laminate with 10k/10k properties
- Removable insulated liner with 150g insulation in body and 100g in arms
- Shock cord adjustable bottom hem
- Removable/adjustable hood
- 3M® Scotchlite™ Reflective Material for nighttime visibility

**WARMTH**

**BREATHABILITY**

**VERSATILITY**

**CROSSOVER**

**SWITCHBACK BIB/PANT**

**DWR**

**3M Thinsulate**  
INSULATION

**3M Scotchlite**  
Reflective Material

**YKK**  
ZIPPERS

**VERSATILE, PREMIUM BIB FEATURES ZONAL INSULATION AND EASY CONVERSION TO PANTS**

- Durable 300 denier poly shell is tear- and snag-resistant and treated with superior DWR to shed snow and water from the outer shell
- Features TECH54™ bonded internal laminate with 10k/10k properties
- Insulated with 150g insulation in the front and 100g in the back
- 3M® Scotchlite™ Reflective Material for nighttime visibility
- Storm cuffs with boot lace retention snaps
- Two inner thigh vents
- Two-way front zipper
- Removable suspenders allow bib to be converted to pant

**WARMTH**

**BREATHABILITY**

**VERSATILITY**

**MAXIMUM VERSATILITY**



Remove the insulated liner without sacrificing waterproof breathability, while increasing versatility for changing ride conditions.



**TECH54**  
5K/5K



**BLUE**  
Sizes: S-3XL  
2860511



INSULATED

**BLACK**  
Sizes: S-3XL  
2860531

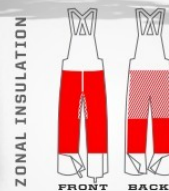

TRAIL

## NORTHSTAR JACKET

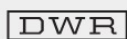

### INSULATED DESIGN DELIVERS EXCEPTIONAL WARMTH AND STYLE

- Durable 300 denier poly shell is tear- and snag-resistant and treated with superior DWR to shed snow and water from the outer shell
- Features TECH54™ bonded internal laminate with 5k/5k properties
- Insulated with 180g insulation in the body and 100g in the arms
- Shock cord adjustable bottom hem
- 3M® Scotchlite™ Reflective Material for nighttime visibility

**WARMTH**

**BREATHABILITY**

**VERSATILITY**

Superior Durable Water Repellency (DWR) prevents precipitation from saturating the exterior of all outerwear pieces.

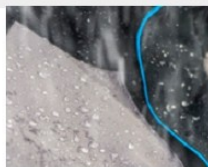

TRAIL

## NORTHSTAR BIB

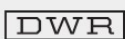

### INSULATED DESIGN FOR ALL-DAY WARMTH AND COMFORT

- Durable 300 denier poly shell is tear- and snag-resistant and treated with superior DWR to shed snow and water from the outer shell
- Features TECH54™ bonded internal laminate with 5k/5k properties
- Insulated with 180g insulation in upper front of legs and lower back and 100g on upper back side
- 3M® Scotchlite™ Reflective Material for nighttime visibility
- Storm cuffs with boot lace retention snaps
- Two external hand pockets and an adjustable waist
- Two-way front zipper

**WARMTH**

**BREATHABILITY**

**VERSATILITY**



# WOMEN'S CROSSOVER GEAR **NEW**

**TECH54™**  
10K/10K

## PARADISE PINK

Sizes: S-3XL  
2860530

INSULATED

## BLACK

Sizes: S-3XL  
2860537

FULL-LENGTH YKK® ZIPPERS ADD VENTING OPTIONS AND MAKE SLIPPING ON AND OFF OVER BOOTS EASIER.

ZONAL INSULATION



FRONT BACK

**CROSSOVER**

## SWITCHBACK JACKET

DWR

3M Thinsulate INSULATION

3M Scotchlite® Reflective Material

YKK ZIPPERS

**PREMIUM JACKET WITH REMOVABLE INSULATED LINER FOR ALL-DAY VERSATILITY**

- Durable 300 denier poly shell is tear- and snag-resistant and treated with superior DWR to shed snow and water from the outer shell
- Features TECH54™ bonded internal laminate with 10k/10k properties
- Removable liner with 150g insulation in body and 100g in arms
- Shock cord adjustable bottom hem
- Removable/adjustable hood
- 3M® Scotchlite® Reflective Material for nighttime visibility

**WARMTH** ██████████

**BREATHABILITY** ██████████

**VERSATILITY** ██████████

**CROSSOVER**

## SWITCHBACK BIB

DWR

3M Thinsulate INSULATION

3M Scotchlite® Reflective Material

YKK ZIPPERS

**PREMIUM BIB FEATURES ZONAL INSULATION AND BREATHABLE WATERPROOFNESS**

- Durable 300 denier poly shell is tear- and snag resistant and treated with superior DWR to shed snow and water from the outer shell
- Features TECH54™ bonded internal laminate with 10k/10k properties
- Insulated with 150g insulation in the front and 100g in the back
- 3M® Scotchlite® Reflective Material for nighttime visibility
- Storm cuffs with boot lace retention snaps
- Two thigh vents

**WARMTH** ██████████

**BREATHABILITY** ██████████

**VERSATILITY** ██████████

**MAXIMUM VERSATILITY**



Remove the insulated liner without sacrificing waterproof breathability, while increasing versatility for changing ride conditions.



**TECH54™**  
5K/5K

**BLACK/PINK**  
Sizes: S-3XL  
2860524



## NORTHSTAR JACKET

**DWR**    **3M Thinsulate** INSULATION    **3M Scotchlite™** Reflective Material    **YKK** ZIPPERS

### INSULATED DESIGN DELIVERS EXCEPTIONAL WARMTH AND STYLE

- Durable 300 denier poly shell is tear- and snag-resistant and treated with superior DWR to shed snow and water from the outer shell
- Features TECH54™ bonded internal laminate with 5k/5k properties
- Insulated with 180g insulation in the body and 100g in the arms
- Shock cord adjustable bottom hem
- 3M® Scotchlite® Reflective Material for nighttime visibility
- Flattering fit and style designed for women

**WARMTH**

**BREATHABILITY**

**VERSATILITY**

Superior Durable Water Repellency (DWR) prevents precipitation from saturating the exterior of all outerwear pieces.







**BLUE/ORANGE**

Sizes: S-XL  
2860538

**TECH54**

5K/5K

**NAVY**

Sizes: S-XL  
2860542



**BLACK**

Sizes: S-XL  
2860543

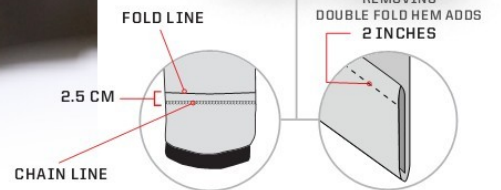

NEW IMPROVED FIT ON ALL TECH54™ KIDS OUTERWEAR & GROW WITH ME BIBS

## SWITHCHBACK JACKET

- Durable 300 denier poly shell is tear- and snag-resistant and treated with superior DWR to shed snow and water from the outer shell
- Features TECH54™ bonded internal laminate with 5k/5k properties
- Removable liner with 150g insulation in body and 100g in arms
- Shock cord adjustable bottom hem
- Two external hand pockets, one external chest pocket
- 3M® Scotchlite® Reflective Material for nighttime visibility

**WARMTH**

**BREATHABILITY**

**VERSATILITY**

## SWITHCHBACK BIB

- Durable 300 denier poly shell is tear- and snag-resistant and treated with superior DWR to shed snow and water from the outer shell
- Features TECH54™ bonded internal laminate with 5k/5k properties
- Insulated with 150g insulation in the front and 100g in the back
- 3M® Scotchlite® Reflective Material for nighttime visibility
- Grow With Me Extension feature adjusts as your child grows taller
- Two external hand pockets

**WARMTH**

**BREATHABILITY**

**VERSATILITY**



## YOUTH BEANIE

Navy/Pink | 2860677  
Blue/Orange | 2860678







# LAYERING



NAVY **NEW**  
S-3XL | 2860552

## TRAIL MID-LAYER

**BREATHABLE FLEECE MID-LAYER IS PERFECT FOR ADDING WARMTH OR AS A STANDALONE SHIRT**

- Extra layer of warmth for when you need it
- 280 grams of breathable fleece and a wear-resistant polyester face
- Designed to fit under outer shell when riding
- Wind block layer on chest for added warmth and wind protection



LAYER:  
MID



GRAY **NEW**  
S-3XL | 2860548

## MID-LAYER

**LAYER FOR VERSATILITY AND WARMTH WITH THIS BREATHABLE FLEECE MID-LAYER**

- Extra layer of warmth which you can add or subtract depending upon activity and temperature
- 280 grams of breathable fleece and a wear-resistant polyester face
- Designed to fit under outer shell when riding



LAYER:  
MID

## WOMEN'S

BLACK  
S-3XL | 2860550



## **NEW** TECH QUARTER-ZIP

**EXCELLENT FOR LAYERING OR AS A COMFORTABLE AND STYLISH SHIRT**

- High-performance garment is ideal as a mid-layer riding or as a standalone layer
- Four-way stretch material is breathable and moisture-wicking to keep you warm and dry
- Cut and sewn for a contoured fit

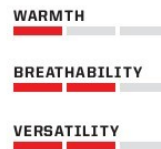

LAYER:  
MID





MEN'S



BLACK/LIME  
S-3XL | 2860544



BLUE/ORANGE  
S-3XL | 2869919

# SOFTSHELL JACKET

**LIGHTWEIGHT PERFORMANCE THAT'S SURPRISINGLY WARM AND PERFECT FOR EVERYDAY WEAR**

- Casual jacket armed with rugged and warm features for everyday wear
- Superior DWR prevents precipitation from saturating the jacket's exterior
- Lined with 280 grams of soft fleece for warmth
- Removable hood and underarm venting, three external pockets, and one internal chest pocket

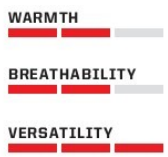

WOMEN'S

PURPLE/LIME  
S-3XL | 2860547



# FIND YOUR PERFECT HELMET

No matter your riding style or personal preference, Polaris® has the perfect helmet choice for you.



## MOTO

- For maximum ventilation and versatility
- Goggle and lens selection
- Convertible for summer use
- 509® Partnership



## FULL

- Maximum protection from elements
- Full anti-fogging protection
- Wide field of view
- Electric shield optional

## SAFETY RATINGS EXPLAINED

**DOT:** Certification from the United States Department of Transportation

**ECE:** Standards set by the Economic Commission for Europe; similar to the DOT standards

## GET THE PERFECT FIT

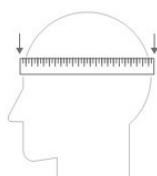

### MEASURE

Measure the circumference here for the proper fit. Make sure the inner lining fits snugly around your head without causing pain.



### MOVEMENT

Move the helmet side to side. Your scalp should move with it.



### CHINSTRAP

Check with your finger. If properly fit, your finger shouldn't fit between your chin and the strap.

## HELMET SIZING GUIDE

SIZE	XS	S	M	L	XL	2XL	3XL
SIZE CODE	00	02	03	06	09	12	14
HAT SIZE	6 3/4	6 7/8-7	7 1/8-7 3/4	7-7 1/2	7 5/8-7 3/4	7 7/8-8	8
CIRCUMFERENCE	20 7/8"-21 1/4" (53-54 cm)	21 5/8"-22" (55-56 cm)	22 3/8"-22 3/4" (57-58 cm)	23 1/8"-23 5/8" (59-60 cm)	24"-24 3/8" (61-62 cm)	24 3/4"-25 1/8" (63-64 cm)	25 1/4"-26" (65 cm)

## DURABLE, ULTRA LIGHTWEIGHT, CARBON FIBER

### SHELL

- Full carbon fiber shell

### WEIGHT

- 1100 grams

### FEATURES

- Fidlock<sup>®</sup> magnetic chin strap technology
- Revolutionary neck brace-ready shell profile
- Removable breath box included
- Universal camera mount included
- Eight intake / exhaust vent ports
- Fully convertible between winter and summer use
- Three outer shell molds across eight sizes for excellent fit
- DOT- and ECE 22.05-approved



### CARBON MATTE

Sizes: S-3XL  
2867814

## 509 FOR POLARIS<sup>®</sup>

509<sup>®</sup> delivers the best in modern helmet and goggle integration, with every helmet and goggle designed to fit and seal the elements out together perfectly.





# 509® ALTITUDE HELMET

STYLISH, LIGHTWEIGHT HELMET WITH 509® FIT AND FINISH

### SHELL

- Thermoplastic poly alloy outer shell

### WEIGHT

- 1260 grams

### FEATURES

- Revolutionary neck brace-ready shell profile
- Specially designed expanded polyurethane chin insert
- Eight intake/exhaust vents
- Universal camera mount included
- Removable breath box included
- Three outer shell molds across eight sizes for excellent fit
- DOT- and ECE 22.05-approved



### LIME

Sizes: S-3XL  
2868539

### GRAY

Sizes: S-3XL  
2867817

# FIDLOCK®

## MAGNETIC TECHNOLOGY

The Carbon Matte helmet features Fidlock® technology, an easy-on and easy-off magnetic closure device that delivers a quick, secure closure every time.

 EASY ONE-HAND OPENING

 EVEN WITH GLOVES

 DOT & ECE APPROVED



# NEW 509<sup>®</sup> DELTA R3 HELMET



APPAREL

RIDING GEAR

LAYERING

HELMETS

GOOGLES & GLOVES

BOOTS & BEANIES

LIFESTYLE

OGIO BAGS

## THE DELTA R3 2.0 IS THE ULTIMATE ALL-IN-ONE SNOWMOBILE HELMET

### SHELL

- Lightweight Polycarbonate

### WEIGHT

- 1680 grams

### FEATURES

- Dual Sport, Full Face, or Open Face configuration options
- Dual-pane anti-scratch, anti-fog coated ITO electric clear shield
- Comes standard with the Fidlock<sup>®</sup> easy-open magnetic strap buckle
- Drop-down internal sun shield (amber)
- Includes removable silicone breath box
- Removable cold weather chin curtain
- Adjustable forehead ventilation ports
- Push-button removable shield
- Removable/washable liner and cheek pads
- Dual-density EPS
- ECE- and DOT-approved



### BLACK/LIME

Sizes: XS-2XL  
2860562

### BLACK

Sizes: XS-2XL  
2860560







# REVOLVER 509® SNOW GOGGLE

PREMIUM PERFORMANCE FROM OUR MOST ADVANCED MATERIALS

## 509® FOR POLARIS®

- Innovative pivot lens lock technology allows lens to pivot up and away from frame
- Quickly release moisture and prevent fogging when stopped
- Dual-frame technology and triple foam face for comfort and a perfect seal
- Oversized spherical lens delivers optimal peripheral vision
- Maximum anti-fog and scratch-resistance
- Outrigger support for strap provides a perfect "inside-the-helmet" fit for today's moto-style helmets

POLARIZED



BLACK  
2868528

MIRRORED



ORANGE  
2868529

POLARIZED



BLACK  
2868531

## SINISTER X5 509® SNOW GOGGLE

FEATURING EXCELLENT VISIBILITY, ANTI-FOG PERFORMANCE, AND DURABILITY

- Incredible style and premium performance for any rider
- The Outrigger mounting strap allows the goggles to seal tight to your face
- Unique Phantom frame technology eliminates goggle frame intrusion into field of view
- Durable polycarbonate lens is both scratch- and fog-resistant
- Oversized foam seals gaps between helmet and goggle frame for maximum warmth
- Choose from a wide range of replacement lenses in multiple colors and finishes

LIME  
2868530







**NEW**

GRAY  
2860563



RED  
2869538



LIME  
2869537



BLACK  
2868532



# KINGPIN 509® SNOW GOGGLE

## PREMIUM MATERIALS IN AN AFFORDABLE PACKAGE

- Oversized spherical lens delivers optimal peripheral vision
- Maximum anti-fog and scratch-resistance
- Contoured frame and triple-layer foam seals out cold and snow
- Removable nose piece delivers versatile cold weather protection
- Quick-change lens technology for fast lens tint swaps

## HOW TO CHOOSE THE PERFECT LENS FOR EVERY LIGHT CONDITION

CARRY MULTIPLE LENSES SO YOU CAN EASILY ADJUST FOR LIGHTING FROM DAWN TO DUSK



**CLEAR**

- Delivers superior low-light visibility
- Increases contrast in cloudy conditions



**YELLOW**

- Enhances flat-light terrain definition
- Delivers superior depth perception

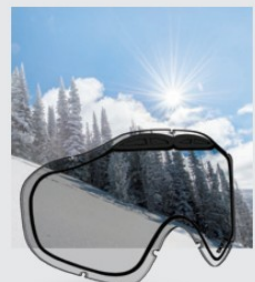

**SMOKE**

- Cuts down brightness without distorting color
- Reduces eyestrain

### LENS COATINGS:



**MIRRORED**

- Reduces glare by reflecting light
- Maintains visibility of LCD readouts
- Paired with lighter tints to offset darkening



**POLARIZED**

- Substantially reduces glare and blinding
- Blocks horizontal light waves
- Decreases eyestrain



# MOUNTAIN GLOVES



Sizes: S-3XL  
2868522

MEDIUM

## MOUNTAIN LEVEL 2



A PERFECT BLEND OF THIN, LIGHTWEIGHT MATERIAL AND WARMTH

- Polyurethane palm for excellent grip while isolating hands from vibration
- Moisture-wicking liner keeps hands dry; 100 grams of insulation for warmth
- Backhand Armor provides protection from branches and debris
- Features adjustable wrist enclosures and an integrated goggle squeegee

### INSULATION



### PADDING



### GRIP



# TRAIL GLOVES



Sizes: S-3XL  
2867743

STANDARD



Sizes: S-3XL  
2868520

MEDIUM

## TRAIL LEVEL 1



POPULAR VALUE-PACKED GLOVE FOR TRAIL RIDING

- Synthetic leather palm with silicone print for a sure grip
- Fully insulated with 100 grams on the back of the hand and 60 grams on the palm
- Night riding safety with built-in 3M<sup>®</sup> Scotchlite<sup>®</sup> Reflective Material
- Adjustable wrist strap and gauntlet shock cord closure
- Dry-zone anti-slip insert
- Built-in goggle squeegee on backside of glove to keep vision clear

### INSULATION



### PADDING



### GRIP



## TRAIL LEVEL 2



VERSATILE PERFORMANCE WITH A PERFECT BLEND OF MATERIAL

- Over-jacket gauntlet seals out cold and snow, ideal for trail riding
- Polyurethane palm for optimum grip while isolating hands from vibration
- Moisture-wicking liner keeps hands dry; 100 grams of insulation for warmth
- Backhand Armor provides protection from frost and ice chunks
- Features adjustable wrist enclosures and an integrated goggle squeegee

### INSULATION



### PADDING



### GRIP





Sizes: S-3XL  
2868523

EXTREME

### MOUNTAIN LEVEL 3



#### OUR WARMEST SHORT-CUFF RIDING GLOVE COMBINED WITH MOBILITY

- Leather palm combines superior grip and long-lasting wear qualities
- Moisture-wicking liner keeps hands dry; 160 grams of insulation for maximum warmth
- Backhand Armor provides protection from branches and debris
- Features adjustable wrist enclosures and an integrated goggle squeegee



### THE PERFECT GLOVE FOR EVERY RIDER.

No matter how you ride, there's a Polaris Engineered™ glove to help you make the most of every ride. The right gloves deliver the perfect amount of warmth while keeping your hands dry and comfortable for hours on end.



Sizes: S-3XL  
2868521

EXTREME

### TRAIL LEVEL 3



#### OUR WARMEST LONG-CUFF TRAIL RIDING GLOVE FOR EXCELLENT WARMTH

- A long wrist featuring an over-the-jacket gauntlet seals out snow and cold with pull-tight shock cords
- Leather palm combines superior grip and long-lasting wear qualities
- Moisture-wicking liner keeps hands dry; 200 grams of insulation for maximum warmth
- Backhand Armor provides protection from frost and ice chunks
- Features adjustable wrist enclosures and an integrated goggle squeegee



MAKE SURE YOUR HANDS STAY WARM WHEN THE NIGHTTIME COLD SETS IN. PACKING MULTIPLE GLOVES GUARANTEES MAXIMUM COMFORT.





# BOOTS



ICE LOCK® SOLE TECHNOLOGY



600 GRAMS OF 3M® THINSULATE® INSULATION

### BOA® SYSTEM VS. LACES

Push to engage. Turn to tighten. Pull for quick release. The BOA® lacing system is easier to get on and off than traditional lace-up boots and gives a perfect fit with the turn of a knob. Even with gloves on.

**3M**  
**Thinsulate**  
INSULATION

**3M** Scotchlite®  
Reflective Material

## SWITCHBACK BOOT

### PERFORMANCE, WARMTH, AND COMFORT

- Dry-Lex® membrane keeps feet dry and 3M® Thinsulate® delivers unmatched warmth for all-day comfort
- Constructed from durable leather for long-lasting wear season after season
- Lightweight design is extremely comfortable and perfect for active riders
- Ice Lock® sole with microscopic glass shards for sure grip on slippery surfaces

**INSULATION**



**TRACTION**



**WEIGHT**



### BOA® SYSTEM

Sizes: 5-14  
2868527



# BEANIES



APPAREL

RIDING GEAR

LAYERING

HELMETS

GOOGLES & GLOVES

BOOTS & BEANIES

LIFESTYLE

OGIO BAGS

A beanie can be the perfect item to put on when you take your helmet off. It is lightweight, warm, and means no one will see your mussed hair. Priorities. Tech Mesh Beanies feature Carbon ASR heat-regulating technology, which uses carbon fibers to absorb your body's warmth, store it and release it when needed, making these beanies the most advanced on the market.

MEN'S



**NORTHERN STAR BEANIE**

Black | 2867751  
Gray | 2867752



**NEW**  
**MEN'S DASH BEANIE**

Black | 2860599

WOMEN'S



**WOMEN'S MOUNTAIN BEANIE**

Purple | 2860673



**WOMEN'S POM BEANIE**

Pink | 2860604



**POLARIS BEANIE**

Black | POL691  
Pink | POL692



**POLARIS BANDANA**

Black | POL632  
Blue | POL635  
Pink | POL695



**FLEECE COLLAR**

Black | ME2023



**MOUNTAIN BALACLAVA**

- Laser-cut breath holes
- Windproof 4-way stretch material blocks wind in key areas while providing extreme comfort

One-Size  
2867745





# MEN'S LIFESTYLE



### CORE FULL ZIP

Black/Lime | S-3XL | 2860566

**NEW**

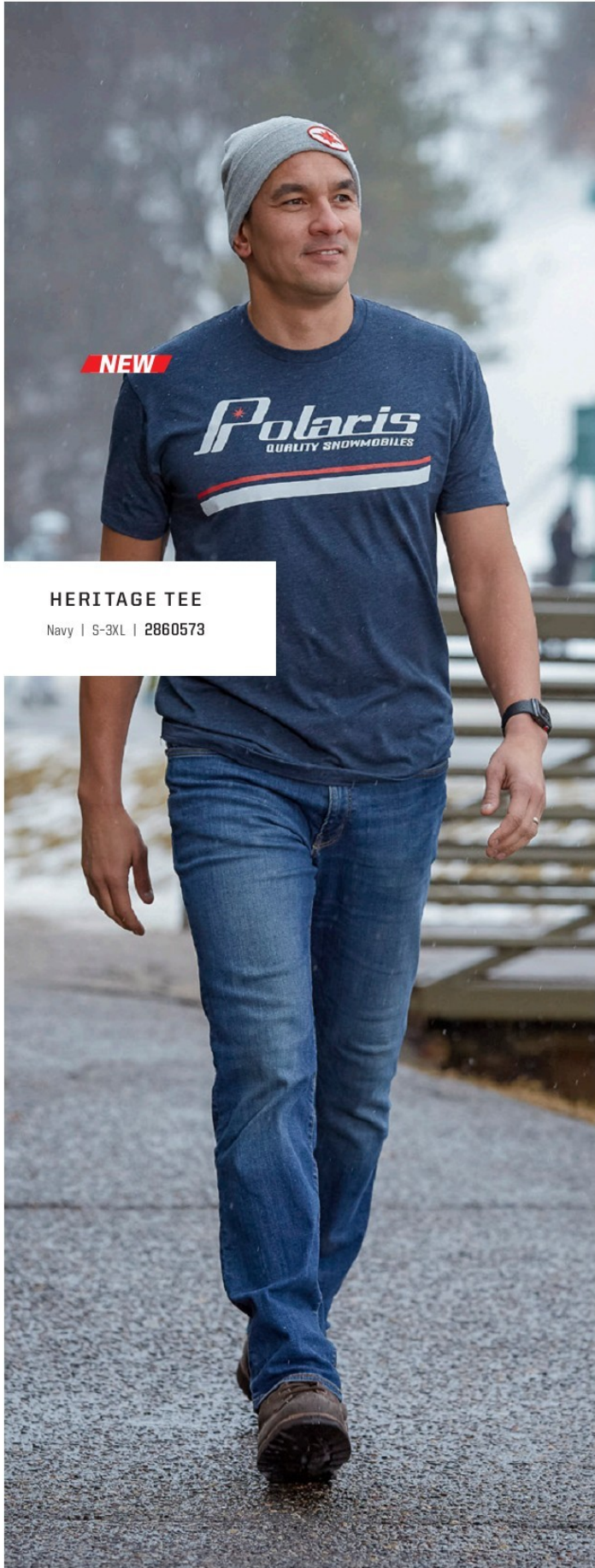

### HERITAGE TEE

Navy | S-3XL | 2860573

**NEW**



**NEW**

### FUSION LONG SLEEVE

Black | S-3XL | 2860568



### RETRO LOGO HOODIE

Charcoal/Lime | S-3XL | 2868578  
Black | S-3XL | 2869549





**NEW**

**ROSEAU TEE**

Black | S-3XL | 2860588



**BADGE TEE**

Black | S-3XL | 2860578  
Royal Heather | S-3XL | 2860579



**4SCENE TEE**

Black | S-3XL | 2860576  
Blue/Orange | S-3XL | 2860577



APPAREL

RIDING GEAR

LAYERING

HELMETS

GOOGLES & GLOVES

BOOTS & BEANIES

LIFESTYLE

OGIO BAGS





**RETRO PULLOVER HOODIE**

Gray | S-3XL | 2860590



**CORE FULL-ZIP**

Black | S-3XL | 2860567

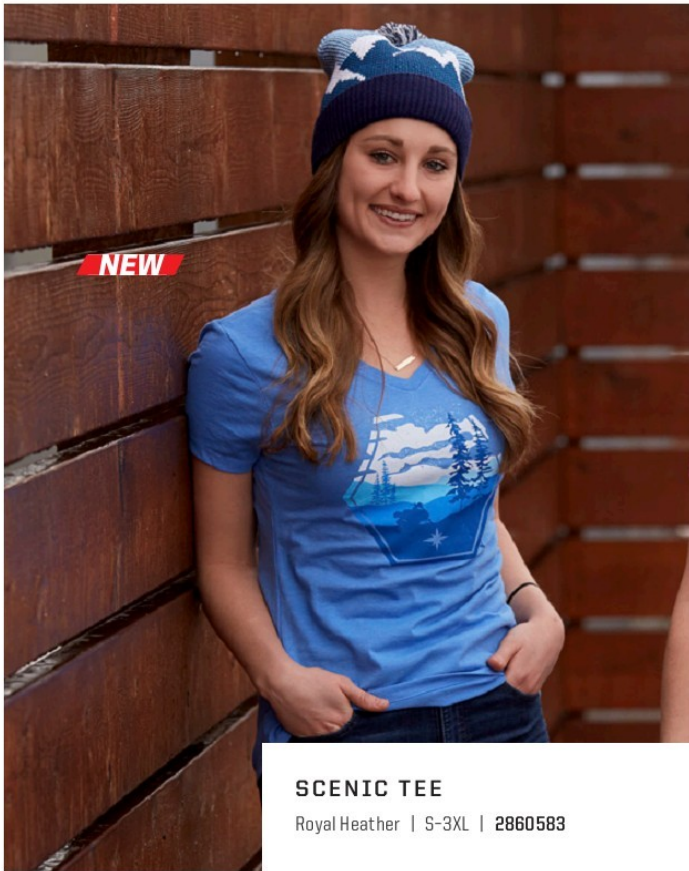

**SCENIC TEE**

Royal Heather | S-3XL | 2860583



**MOUNTAIN TEE**

Black | S-3XL | 2860580





# CAPS



APPAREL

RIDING GEAR

LAYERING

HELMETS

GOOGLES & GLOVES

BOOTS & BEANIES

LIFESTYLE

OGIO BAGS



### **NEW** HERITAGE CAP

Navy | One-Size | 2860592

### **NEW** FUSION SNAPBACK CAP

Black | One-Size | 2860595  
Gray | One-Size | 2860596



### **NEW** ELLIPSE PATCH CAP

Black | One-Size | 2860597

### RETRO CAP

Gray/Red | One-Size | 2869542



### MEN'S

### RETRO TRUCKER CAP

MEN'S  
Navy | One-Size | 2869539

### WOMEN'S

WOMEN'S  
Blue | One-Size | 2869545



### CORE CAP

Navy | One-Size | 2869544  
Black | One-Size | 2867762







**OGIO®  
9800 RIG ROLLER**

- SLED (Structural Load Equalizing Deck) system for increased durability and handling in the harshest of conditions
  - Wide-mouth LID opening for easy access to all gear compartments
  - Large main compartment with adjustable dividers and padded helmet chamber
  - iFOM (integrated foam) construction throughout for added gear protection
  - Heavy-duty oversized wheels with extra clearance
  - Telescoping pull handle
- 2867869



**OGIO®  
SLAYER GEAR BAG**

- Separate internal pockets
  - Heavy-duty 900D fabric with eco-friendly PVC backing specs
  - Dimensions: 80 cm H x 40 cm W x 46 cm D
- 2867871



**OGIO®  
BIG MOUTH  
GEAR BAG**

- Extra-large access to main volume
  - Ogio® SKID system includes large diameter wheels and axles
  - Dimensions: 80 cm H x 40 cm W x 46 cm D
- 2867870



**OGIO®  
AXIL LAPTOP  
BACKPACK**

- Airport checkpoint-friendly laptop compartment fits most 17" laptops
  - Multiple organization pockets
  - 840D double ripstop face coated
  - Dimensions: 44 cm H x 33 cm W x 23 cm D
- 2867872





APPAREL

RIDING GEAR

LAYERING

HELMETS

GOOGLES & GLOVES

BOOTS & BEANIES

LIFESTYLE

OGIO BAGS





THE RIGHT ACCESSORIES TO  
TRAVEL TO EPIC PLACES AND

**RAISE YOUR  
BACKCOUNTRY  
BAR.**



Deep snow. Bluebird skies. Epic lines. You live to explore the backcountry. Elevate your ride with safety, protection, and storage accessories designed to take you places you have never been before.

## TOP PICKS

### SAFETY

---

#### TETHER SWITCH

Shuts engine off when rider is separated from sled: [PG. 65](#)

### PROTECTION

---

#### MONARCH FRONT BUMPER

Snow free protection with multiple lift points: [PG. 56](#)

### STORAGE

---

#### WINDSHIELD/DASH BAG

Easy access to necessities: [PG. 44](#)

#### GOGGLE BAG

For additional goggles or lenses for changing light conditions: [PG. 45](#)

#### TUNNEL STORAGE

Pack the day's essentials: [PG. 46](#)

#### FT2 RACK BAG

Maximize your storage while riding 2-up: [PG. 54](#)



THE RIGHT ACCESSORIES TO GO FROM  
ADRENALINE TO CONNECTIONS AND

# UNLOCK THE DAY'



Memories aren't made inside, they're carved in snow—and often at a moment's notice. Quickly and easily adapt your sled to take advantage of whatever the day brings, and unlock the potential of every ride with Polaris Engineered Accessories™.



# S POSSIBILITIES.



## TOP PICKS

### CUSTOMIZATION

#### BUMPERS

PG. 56

#### SPINDLES

PG. 69

#### HOODS & SIDE PANELS

PG. 63

#### RUNNING BOARDS

PG. 60

#### SKIS & SKI HOOPS

PG. 69

#### WRAPS

Unique design for your sled: PG. 63



THE RIGHT ACCESSORIES  
TO GO THE DISTANCE BECAUSE

# ADVENTURE AWAITS IN ANY CONDITION.







Planning for a multi-day ride means choosing Polaris Engineered Accessories™ as a trusted partner. Make sure your sled is ready for all conditions and terrain – only with the perfect combination of comfort, storage, and protection made exclusively for your sled.

**TOP PICKS**

**COMFORT**

---

**DRIVER GAUNTLETS**

Keep hands warm and out of the wind: **PG. 65**

**HEATED SEATS**

Warm up your core: **PG. 55**

**STORAGE**

---

**ADVENTURE TUNNEL BAG**

Pack for your overnight adventure: **PG. 47**

**UNDERHOOD HEATED BAG**

For a warm second pair of gloves & goggles: **PG. 45**

**SAFETY**

---

**CELL PHONE CHARGING BAG**

Keep your phone charged: **PG. 45**

**MIRRORS**

Easy view of riding group: **PG. 64**

**PROTECTION**

---

**MONARCH FRONT BUMPER**

Additional protection on & off trail: **PG. 56**



THE RIGHT ACCESSORIES TO  
WORK HARD, PLAY HARD AND

# PUT MORE FUN



Unlock the true versatility in your sled by adding the perfect combination of Polaris Engineered Accessories™ designed to enhance both work and play. They're designed and built exclusively for your sled to elevate the most important ride experience—your own.



# IN EVERY DAY



## TOP PICKS

### STORAGE

#### VERSA CARGO RACK

Multiple tie-down possibilities: [PG. 50](#)

#### VERSA CARGO BOX

Weather-proof storage: [PG. 50](#)

#### WINDSHIELD BAG

Easy access to necessities: [PG. 44](#)

### COMFORT

#### DRIVER GAUNTLETS

Keep hands warm and out of the wind: [PG. 65](#)

#### HEATED SEAT

Warm up your core: [PG. 55](#)

#### FULL COVERAGE WINDSHIELD

Ultimate wind protection: [PG. 58](#)

### UTILITY

#### HD FRONT BUMPER

Versatile 3.2 cm receiver applications: [PG. 56](#)

#### 1500 LB WINCH

Multi-position mounts for increased usability: [PG. 51](#)

### PLAY

#### ICE AUGER MOUNT

[PG. 50](#)

#### GUN & ROD LOCKER MOUNT

[PG. 50](#)



# POLARIS®

ENGINEERED PARTS  
ACCESSORIES & APPAREL

## ENGINEER A MORE PERFECT RIDE.

Polaris Engineered Accessories™ are the only accessories engineered and designed exclusively with your sled. That's why every accessory fits perfectly and is tested, trusted, and proven to make your next ride an even better one. Whether that's more comfort, personal style, control, storage, or more peace of mind, only Polaris Engineered Accessories guarantee the ultimate ride experience.

### ACCESSORIES TAILORED TO ELEVATE YOUR RIDE

- PERFECT FIT
- SEAMLESS INTEGRATION
- FACTORY COLOR MATCHING
- LIMITLESS COMBINATIONS

STORAGE  
P. 44

RUNNING BOARDS  
P. 60

## POLARIS® PARTNERS WITH THE BEST

We choose our partners carefully, selecting only the best in snowmobiling. Every accessory is rigorously tested and validated by Polaris® standards to ensure seamless integration.



**CALIBER™**

Caliber is dedicated to producing the highest quality products to make transporting your snowmobile safe and easy.



**HANDLEBARS**  
P. 64

**WINDSHIELDS**  
P. 58

**BUMPERS**  
P. 56

**SKIS**  
P. 69

**SEATING**  
P. 54



**LOCK & RIDE**

**EASY ON & EASY OFF.**

Items with the Lock & Ride® logo feature our exclusive easy-on, easy-off installation technology. Engineer the perfect ride with accessories like storage racks or passenger seats that install quickly and efficiently without tools. And when you don't need them, removal is simple.



**ARCTICFX®**

The leader in premium custom graphics, Arctic FX is dedicated to delivering the best custom snowmobile graphics in the industry.



**ÖHLINS®**

Industry leader in shock technology for Auto, ATV, MC, MX and Snowmobile.



**CAMSO®**

An industry leader in track technology, Camso offers cutting-edge tracks for every snowmobile discipline.



**WOODY'S®**

Woody's is a leading producer of studs, carbides, and more that deliver unrivaled traction and performance for every kind of ride.



# STORAGE & RACKS



## WINDSHIELD / DASH STORAGE

Perfect for items you need quick and easy access to.

### WINDSHIELD BAG AXYS

- Bag installs inside base of windshield using stock push-dart fasteners
- Compression-molded semi-rigid material
- Uses engine heat to warm/dry goggles and gloves

Low Pro | 2880481  
ALL AXYS® AND POLARIS® TITAN®. ONLY FITS WITH LOW WINDSHIELD

Large | 2880374  
ALL AXYS® AND POLARIS® TITAN®. DOES NOT FIT WITH LOW WINDSHIELD



### WINDSHIELD REPLACEMENT BAG AXYS

- Combination windscreen and storage bag adds function and style
- Perfect for deep snow applications where over-the-hood sightlines are required
- Delivers quick access to personal items
- Semi-rigid design retains its shape even when empty or when the sled needs to be rolled to maneuver out of a stuck position

2882917  
ALL AXYS®



### MOUNTAIN DASH BAG AXYS

- Semi-rigid, compression-molded bag installs on dashboard
- Convenient, protected storage for two bottles of water, goggles, and gloves
- Installs easily, holds its shape empty or full

2880375  
PRO-RMK® MY16-20, SKS 155 MY16-20, RMK® ASSAULT® MY16-20



### ULTIMATE DEFROST BAG PRO-RIDE

- Provides warm, dry place for goggles, gloves, and more
- Rigid construction holds its shape
- Durable 1,680-denier black ballistic nylon with water-resistant coating

2879090  
MY10-20 PRO-RIDE®, INCLUDES INDY® AND VOYAGEUR®, P.I.D.D. NOT INCLUDED



## HANDLEBAR / GOGGLE STORAGE

Even more storage, centrally located for easy access.

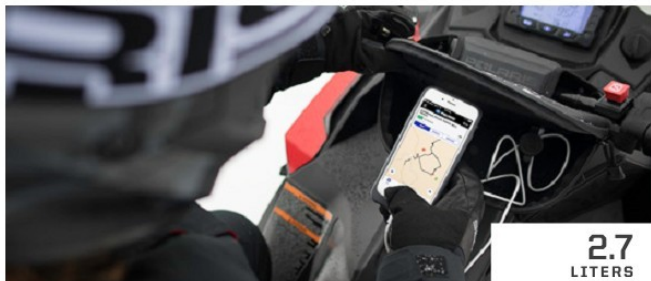

2.7 LITERS

### CELL PHONE CHARGING BAG **AXYS**

- Charge your cell phone while the engine is running
- Includes wire harness, which connects to the sled's electrical system
- Use your device's charging cable to attach via USB connection inside bag

2883687  
ALL MY16-20 PRO-RMK®

2883786  
ALL MY15-20 RUSH®, MY15-20 SWITCHBACK®,  
MY18-20 TITAN®, MY17-20 SWITCHBACK®,  
ASSAULT®, MY19-20 INDY® 129, MY20 INDY®  
137. DOES NOT FIT WITH ROX RISER



5.8 LITERS

### HEATED UNDERHOOD STORAGE **AXYS**

- Underhood storage is ideal for storing goggles and keeping them defrosted
- Perfect for cold rides or deep powder days when swapping goggles is necessary
- Attaches securely using a bracket with fasteners and Velcro® straps

2882117 **★ TOP SELLER**  
ALL AXYS®, DOES NOT FIT WITH TITAN®



2.7 LITERS

### GOGGLE HANDLEBAR BAG **AXYS** **★ TOP SELLER**

- Conveniently access spare goggles from the driver's seat
- Attaches directly to handlebars with secure Velcro® straps

2882823  
ALL AXYS®



3.4 LITERS

### UNDERHOOD GOGGLE BAG **PRO-RIDE**

- Heavy-duty nylon bag mounts under hood above exhaust
- Gloves, goggles, etc. are warmed by engine heat

2878735  
ALL PRO-RIDE®



2882824  
ALL SNOWMOBILES

### HANDLEBAR MAP BAG **AXYS** **PRO-RIDE**

- Clear poly window displays trail map for easier navigation
- Attaches easily with all-weather Velcro® strips



## UNDERSEAT STORAGE

Storage for items like a first aid kit or water bottles.



7.7 LITERS

### BURANDT ADVENTURE UNDERSEAT BAG **AXYS** **★ TOP SELLER**

- Dual side-access zippers provide access to cargo when bag is installed
- Semi-rigid shell holds its shape, full or empty
- Engineered to withstand extreme riding conditions

2881056  
MY16-20 AXYS® PRO-RMK®,  
AXYS® SKS 155, AXYS®  
RMK® ASSAULT®



11.8 LITERS

### WATERPROOF UNDERSEAT LINER BAG **AXYS**

- Fits inside stock underseat bag
- Perfect when riding in heavy, wet snow or backcountry powder

2882857  
ALL MY17-20 SBA, MY18-20  
SKS 146, MY19-20 INDY® 129,  
MY20 INDY® 137





## TUNNEL STORAGE

Perfect for holding enough items for a destination trip.



WEATHER-RESISTANT LID

ADJUSTABLE VELCRO® DIVIDERS

FITS OVER THE TOP OF THE PREMIUM BACKCOUNTRY TUNNEL BAG

**32.0**  
LITERS



LOCK & RIDE

### PREMIUM BACKCOUNTRY TUNNEL BAG AXYS® PRO-RIDE®

- Reinforced high-density EVA compression molding provides high impact resistance and extreme tunnel protection
- Main storage allows for a customized configuration
- Bottom is designed with air flow channel to reduce

heat between the tunnel and bag

**2881979** ★ TOP SELLER

ALL PRO-RMK®, SKS, RMK®, SKS 146, SWITCHBACK® ASSAULT®, INDY® 144, VOYAGEUR®

### PREMIUM BACKCOUNTRY MOUNTAIN JACKET

**2882130**

ALL PRO-RMK®, SKS, RMK®, SKS 146, SWITCHBACK® ASSAULT®, INDY® 144, VOYAGEUR®, REQUIRES PREMIUM LOCK & RIDE® BACKCOUNTRY TUNNEL BAG (2881979)



SMALL

5 CM BUCKLES

OVER-CENTER LOCK & RIDE®

**9.2**  
LITERS



LARGE

WEATHER-RESISTANT LID

**14.8**  
LITERS

LOCK & RIDE

### BURANDT ADVENTURE TUNNEL BAG AXYS® PRO-RIDE®

- 5 cm buckles provide easy access to gear with your gloves on
- Customizable configuration with Velcro® adjustable dividers
- Tray liner is water-resistant to keep your gear dry

Small | **2880969** ★ TOP SELLER

ALL RMK®, AXYS® PRO-RMK®, SWITCHBACK® ASSAULT®

Large | **2880970** ★ TOP SELLER

ALL RMK®, AXYS® PRO-RMK®



★ TOP SELLER

### TRAVERSE TUNNEL BAG AXYS® PRO-RIDE®

- 5 cm buckles make it easy to access your gear with gloves on
- Water-resistant construction
- Attaches in seconds with Lock & Ride® technology

**2883570**

FITS FULL TUNNEL 129" AND LONGER SLEDS WITH T-SLOT ATTACHMENT

**22.0**  
LITERS



**NEW**  
**ADVENTURE TUNNEL BAG** AXYS® PRO-RIDE®

- 5 cm buckles make it easy to access your gear with gloves on
- Includes two waterproof duffels to easily bring gear inside after the ride
- Ample storage space to carry everything you need

2882816

FITS FULL TUNNEL 129" & LONGER SLEDS WITH T-SLOT ATTACHMENT, 129 INCH WILL NEED TO REMOVE STOCK UNDERSEAT BAG TO FIT

**46.4**  
LITERS



**SMALL**  
ULTIMATE SHOVEL BAG

**9.2**  
LITERS



**LARGE**  
ULTIMATE SHOVEL BAG

**12.3**  
LITERS

LOCK & RIDE **ULTIMATE SHOVEL BAG** AXYS® PRO-RIDE®

- Semi-rigid compression-molded material
- Mesh pocket inside exterior shell
- Customize interior with adjustable Velcro® dividers
- Holds secondary shovel head, handle, and essential extra gear (sold separately)
- Shovel sold separately

Small | 2881057 **★ TOP SELLER**

ALL PRO-RMK®, SKS & SWITCHBACK® ASSAULT™

Large | 2882822 **★ TOP SELLER**

ALL PRO-RMK®, RMK®, SKS 155, RMK® ASSAULT™. WILL NOT WORK WITH FUEL CAN RACK ON 155 TUNNELS

Hardware Replacement | 2881260

ALL AXYS® & PRO-RIDE®



LOCK & RIDE **ADJUSTABLE FUEL CAN RACK** AXYS® PRO-RIDE®

- Installs quickly and easily in tunnel's T-slots
- Holds most 9.5 L fuel cans
- Fuel can sold separately; not through Polaris®

Aluminum | 2879790

Matte Black | 2879790-458

FITS FULL TUNNEL 129" & LONGER SLEDS WITH T-SLOT AT ATTACHMENT

**FUEL CAN RACK STRAPS**

7081248

ALL AXYS® & PRO-RIDE®



**SNOBUNJE® RATTLER**

- Deep snow extraction device
- Hook attaches to ski; use handle to pull

2874420

ALL SNOWMOBILES

**SNOWBOARD & SKI RACK** AXYS® PRO-RIDE®

- Multi-use for ski to snowboard applications via brackets
- Minimalist design usage allows room for tunnel bag, backpack, or gas can rack
- Versatile rack allows ability to install on either side of the tunnel

2881251

ALL PRO-RMK®, SKS, RMK® ASSAULT™, VOYAGEUR® 155







## CARGO RACK STORAGE

Strong and durable with versatile bag and accessory options.

### SWITCHBACK® CARGO RACK AXYS®

- Strong, durable aluminum construction
- Easy bolt-on installation; all mounting hardware included

Aluminum | 2880205

Matte Black | 2880205-458

MY15-20 SWITCHBACK® 137

**13.6**  
KG STORAGE



## SWITCHBACK® CARGO RACK BAG OPTIONS



### CARGO RACK BAG

Weather-resistant design helps seal out snow and moisture to keep cargo dry. Durable, semi-rigid, compression-molded design resists impacts.

2881967  
AXYS® SWITCHBACK®,  
(REQUIRES RACK 2880205  
OR 2880205-458)



**22.3**  
LITERS



**7.2**  
LITERS

### SOFT SADDLEBAGS

Expand your storage options with soft-sided saddlebags. Semi-rigid design retains its shape even when empty. Large zippered opening delivers easy storage access. Attaches quickly and securely with all-weather Velcro® strips.

2882094  
MY15-20 SWITCHBACK®, REQUIRES SWITCHBACK® CARGO RACK  
(2880205 OR 2880205-458)

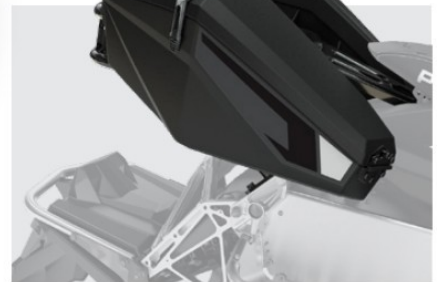

### X2 BACKREST CARGO RACK BAG

Weather-resistant design helps seal out snow and moisture to keep cargo dry. Durable, semi-rigid, compression-molded design resists impacts.

2881966  
AXYS® SWITCHBACK®,  
(REQUIRES RACK 2880205  
OR 2880205-458 AND X2  
BACK REST 2881164)



**10.5**  
LITERS



### UNDERSEAT JOURNEY BAG

Front of bag attaches behind seat using Tuflok® fasteners (included). Center cargo compartment and two side compartments. Durable, semi-rigid, compression-molded design resists impacts.

2880372  
AXYS® RUSH® 6  
SWITCHBACK®,  
DOES NOT WORK WITH  
SWITCHBACK® ASSAULT®



**10.8**  
LITERS

### LOCK & RIDE CARGO RACK SADDLEBAGS

Impact-modified nylon shell and water-resistant removable liner for underseat cargo bag.

2878720  
MY15-20 SWITCHBACK® 137, (REQUIRES 2880205 OR  
2880205-458)



**6.8**  
KG STORAGE

**REAR SPORT RACK** AXYS™

• Easy bolt-on installation; all mounting hardware included

Matte Black | 2880362-458  
MY15-20 RUSH®

Matte Black | 2880363-458  
MY15-20 SWITCHBACK® 137



**CARGO RACK 144"** AXYS™ PRO-RIDE™

• Design offers three-level storage with low, medium, and high cross bars  
• Angled design accommodates tie-down straps to secure cargo

Matte Black | 2881940-458

MY17-20 AXYS® 144, MY18-20 SKS, ALL 550 & 600 VOYAGEUR® MODELS

**REAR SPORT RACK BAG OPTION**



**SPORT RACK BAG**

Bag attaches to rack and behind seat using Tuflok™ fasteners. Durable, semi-rigid, compression-molded design resists impacts.

2881464 **TOP SELLER**  
MY15-20 RUSH®, MY15-20 SWITCHBACK® 137

**15.6**  
LITERS

**CARGO RACK 144" BAG OPTION**



**CARGO BAG 144"**

Semi-compressed with nylon side bag installs securely in cargo rack. Versatile bag can be converted to a single large cargo compartment.

2881968  
MY17-20 AXYS® 144, MY18-20 SKS 146, ALL 550 AND 600 VOYAGEUR® MODELS (REQUIRES CARGO RACK 2881940 OR 2881940-458)

TUNNEL CAPACITY VARIES. PLEASE SEE DECAL ON TUNNEL FOR YOUR VEHICLE'S SPECIFICATIONS

PRO-RIDE™

**INDY®**

**PRO-RIDE® INDY® STORAGE**



**INDY EVO™ TUNNEL STORAGE BAG**

• Provides underseat storage for quick access  
• Compression-molded design provides rigidity  
• Attaches easily with all-weather Velcro® strips

2883671  
MY19-20 INDY EVO™

**9.5**  
LITERS



**HANDLEBAR BAG**

• Provides quick, convenient access to essential items  
• Semi-rigid design retains its shape even when empty  
• Attaches easily with all-weather Velcro® strips

2882829  
PRO-RIDE® INDY®

**3.9**  
LITERS



**LOCK & RIDE TUNNEL BAG**

• Tunnel-top storage provides storage for larger items including clothing and gloves  
• Semi-rigid design retains its shape even when empty  
• Large zippered opening delivers easy storage access

2882788  
PRO-RIDE® INDY®

**15.2**  
LITERS



**UNDERSEAT BAG**

• Take advantage of underseat space with this easy-access storage bag  
• Semi-rigid design retains its shape even when empty  
• Attaches easily with all-weather Velcro® strips

2882786  
PRO-RIDE® INDY®

**8.2**  
LITERS



# TITAN®

**A LOCK & RIDE VERSA REAR CARGO RACK**

- Rugged aluminum powder-coated rear rack delivers versatile storage solutions
- Bolts securely to tunnel and features multiple cargo tie-down points

2882792  
ALL TITAN®

**B LOCK & RIDE VERSA REAR CARGO BOX**

- Heavy-duty roto-molded box mounts to rear luggage rack with Lock & Ride® technology
- Easy-open hinge lid can accommodate an optional padlock for security
- A total of 60.5 liters of storage space

2882793  
ALL TITAN®

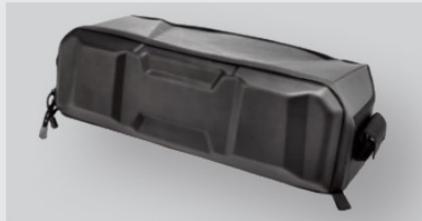

**LOCK & RIDE UNDER-PASSENGER SEAT BAG**

- Take advantage of underseat space with this easy-access storage bag
- Semi-rigid design retains its shape even when empty
- Attaches easily with Velcro® strips

2882807  
ALL TITAN®



**NEW CARGO BOX BUNGEE NET (EXTERIOR) AXYS**

- Expands storage of the Lock & Ride Versa Rear Cargo Box
- Secure extra cargo to the exterior of the cargo box for easy access and increased capacity

2884300  
ALL TITAN®

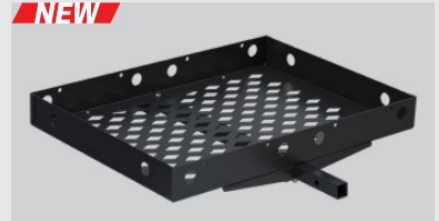

**NEW CARGO RACK FOR FRONT 3.2 CM RECEIVER**

- Hitch mounted cargo rack is perfect for carrying all the gear you need
- Constructed from powder-coated steel, this rack will stand up to the toughest loads

2884259  
ALL TITAN® WITH HD FRONT BUMPER (REQUIRES HD FRONT BUMPER 2882794)



**ICE AUGER RACK**

- Premium steel rack securely holds your ice auger for easy transport

2882799  
ALL TITAN®



**KOLPIN® STRONGHOLD MOUNT**

- Versatile and rugged mount affixes to side of tunnel
- Conveniently accepts accessory gun boots or ice rod lockers
- Retains storage capabilities of rear rack

2882806  
ALL TITAN®

**LOCK & RIDE XL TITAN SCANDI CARGOBOX**



- Cargo box 100 liter with straps. Cargo can also be stored on the lid with straps.

P282  
NOTE: (CARGO BOXES CAN ONLY BE USED WITH 1-UP SEAT, LGR SOLD SEPARATELY.)



- Cargo box with backrest, 100 liter with straps. Cargo can also be stored on the lid with straps.

P283  
NOTE: (CARGO BOXES CAN ONLY BE USED WITH 1-UP SEAT, LGR SOLD SEPARATELY.)



- Cargo box 110 liter with straps. Titan Adventure. Cargo can also be stored on the lid with straps.

P284



### INTEGRATED 680 KG WINCH

- Versatile and rugged winch can clear downed trees or retrieve a stuck snowmobile
- Features a powerful 680 kg capacity
- Includes wireless winch remote
- Mounts to rear of sled with included receiver hitch
- Mounts to front of sled when using Titan® HD Front Bumper (2882794). (Requires 2883850)

**2882798 - WINCH 680Kg**  
ALL TITAN®  
**TITAN® FRONT WINCH ATTACHMENT CABLE**  
• Required for utilization of the winch in the front of your Titan® snowmobile. Requires Titan® HD Front Bumper (2882794)

**2883850 - ATTACHMENT CABLE FRONT**  
ALL TITAN®



### TITAN® LIGHTBAR MOUNT

**2882815**  
ALL TITAN® (REQUIRES HD FRONT BUMPER 2882794)

**PROTECTION: MAXIMUM**

### TITAN® HITCHES

STANDARD HITCH	3.2 CM RECEIVER
<b>2882812</b>	<b>2882795</b>
ALL TITAN®	ALL TITAN®

### TITAN® HITCH ADAPTER

- Bolts onto either the J-hook or Standard hitch to allow them to be used with 3.2 cm receiver installed
- Allows user to change between J-hook, Standard, and Ball hitch without the use of tools

**2882814**  
ALL TITAN®

## HITCHES

For hitches to other Polaris snowmobiles see page 52.

### STAND-ALONE HITCHES



**J-HITCH TITAN SCANDI**  
**B0131**  
4-BOLTS SAFETY HITCH.



**J-HOOK**  
**2882915**  
MY17-20 SBA, MY17-20 SWITCHBACK® SP, MY17-20 RMK® 144, MY18-20 SKS 146, MY19-20 INDY® 129, MY20 INDY® 137 (INCLUDES BUMPER)

**2882918**  
MY17-20 600 VOYAGER® 144

**2882790**  
MY15-20 VOYAGEUR® 550 155, MY15-20 INDY® 550 155

### PRO-RIDE®

## VOYAGEUR® 155" EXTREME REAR RACK

- Strong, durable tubular construction
- Easy bolt-on installation

**2880275**  
ALL 550 INDY® 155



VOYAGEUR RACK & LINER



## CARGO BOX VOYAGEUR 155

**P261**  
INDY 550 VOYAGEUR 155 15-16 155", 15-16, 2017-2018 WITH CARGO RACK 288275 INSTALLED

### PRO-RIDE®

## RMK CARGO RACK LOCK & RIDE



**P285**  
CARGO BOX RMK 155"

**P286**  
CARGO BOX RMK 144"

CARGO BOXES



**P287**  
CARGO BOX FT2 2-UP-SEAT.



# RECEIVER HITCH DRAW BARS



## J-HITCH

B0221, J-Hitch can be mounted on all snowmobile units from MY 1998-2020. Mounts for each model of snowmobile are listed below and are available in black color. More mounts can be purchased just contact your local dealer for hitch to your model of snowmobile.



- » B0130 J-Hitch Widetrack GT/ LX/ IQ
- » B0131 J-Hitch TITAN Safety, 4-Bolt
- » B0221 J-Hitch | MY 1989-2020
- » MN1007 K-Mount AXYS RUSH/ AXYS SWB | MY 15-20
- » MN1002 K-Mount RUSH | MY 11-14
- » MN1002 K-Mount SWB 136" PRO-RIDE | MY 12-14
- » B0255 K-Mount 600/800 INDY XC 129" | MY 2019-
- » B0256 Monteringsatts 600/850 INDY XC137" | MY 2020
- » B0251 K-Mount AXYS RMK 6 SKS 155" | MY 16-20
- » B0254 K-Mount AXYS SKS 146" 600/800 Switchback Assault 144" 800 Switchback SP 144" | MY 2019-
- » B0252 K-Mount AXYS SWB Assault/ SP 144", SKS 146" | MY 18
- » B0245 K-Mount RMK 144" | MY 12-20
- » B0246 K-Mount RMK 155" | MY 12-15
- » B0247 K-Mount RMK 163" | MY 11-15
- » B0248 K-Mount INDY Voyager 550 14, 550 Adventure X2 | MY 14-16
- » B0245 K-Mount 600 INDY VOYAGER | MY 14-16
- » B0236 K-Mount IQ 121" 08-2012, IQ SWB 136" | MY 08-10
- » B0245 K-Mount Switchback 144" | MY 11-15
- » B0244 K-Mount INDY 121", INDY EVO | MY 19-
- » B0232 K-Mount 600 IQ LXT Touring | MY 11-14
- » B0236 K-Mount 550 IQ LXT Touring | MY 11-13
- » B0232 K-Mount Touring | MY 07-12
- » B0234 K-Mount RMK 144" | MY 07-11
- » B0235 K-Mount RMK 155" | MY 07-10
- » B0237 K-Mount 600RR | MY 08-09
- » B0249 K-Mount 550 INDY VOYAGER | MY 15-16
- » B0249 K-Mount 550 INDY Adventure | MY 15-16



# CARBIDE WEAR STRIPS

Carbides need to be sharpened or replaced periodically due to normal wear and use. Rocks, cement, pavement, and road crossings all contribute to carbide wear.

3" - 4" CARBIDE



- Perfect for sleds with a 121" track with 96 studs or less or sleds with 1" lugs taking corners at moderate speeds.

6" CARBIDE



- Ideal for sleds in the 136" track range with up to 1 1/4" lugs or shorter track sleds with more than 96 studs.

8" CARBIDE

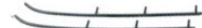

- Best for ultimate performance sleds with a 144" track or longer with paddles and/or the maximum amount of studs.

## CHOOSE YOUR LENGTH

### SINGLE RUNNER

Provides known reliability, handling, and control.

SKI	NOTE	3"	4"	6"	6"	8"
Pro-Steer / Pro-Float	Sold Individually		2879025 <b>★ TOP SELLER</b>		2879026	2879027
Gripper	Sold Individually	2875723 <b>★ TOP SELLER</b>		2877880		2877881

### DOUBLE RUNNER

Provides an increase in steering control in icy conditions and minimizes darting when riding on packed trails. Perfect to pair with a studded track.

SKI	NOTE	SLIM JIM		DOOLY	
		4"	6"	4"	6"
Pro-Steer / Pro-Float / Gripper	Sold Individually	2882956	2882957	2882953	2882954



### BITEHARDER® CARBIDE SHARPENER

- Designed to be used with portable drill for sharpening anywhere
- Carbide wear bar sharpening tool for use on the trail or in the shop
- Quickly and easily puts a fresh edge on wear bars for improved handling
- Delivers more precise and accurate handling, especially in the corners
- Features a long-lasting V-shaped, diamond-coated sharpening stone
- Long-lasting diamond media can sharpen up to 40 wear bars

2882952



**★ TOP SELLER**

### ICE SCRATCHERS

- Direct ice chips into skid to lube and cool hi-fax
- Permits wheel removal on SKS 155, saving 4 lbs.

2882028

ALL AXYS® PRO-RMK®, ASSAULT® RMK®, SKS 155

2876256

PRO-RIDE® RMK®, RMK® ASSAULT®



### RMK® BOGIE WHEEL KIT

- Wheels install on stock skid
- Reduces hi-fax wear on hard pack snow and ice
- A total of 3 pairs can be installed onto a stock skid

2882048

AXYS® PRO-RMK® 174, AXYS® PRO-RMK®, ASSAULT® RMK®, SKS. COMES STANDARD ON SKS 155

2878251

PRO-RIDE®



### XCR TORSION BAR KIT

- Reduces body roll when cornering

2881950

15-20 AXYS® RUSH® & SWITCHBACK®





# SEATS



LOCK & RIDE

## LOCK & RIDE® FT2 PASSENGER SEAT

Standard | 2883637 **★ TOP SELLER**  
MY19-20 INDY® 129, MY20 INDY® 137, MY17-20 SBA,  
MY17-20 VOYAGEUR® 600 144, MY17-20 SWITCHBACK® SP

**NEW** Heated  2884208  
MY19-20 INDY® 129, MY20 INDY® 137, MY17-20 SBA,  
MY17-20 VOYAGEUR® 600 144, MY17-20 SWITCHBACK® SP

INCLUDES BACKREST,  
SEAT AND HANDHOLDS

HEATED GRIPS & PLUG IN FOR  
PASSENGER'S HEATED VISOR

### HANDWARMER POWER KIT

• Required to power the passenger  
handwarmers on MY17-18 AXYS®  
144 sleds

2883851  
SWITCHBACK® SP '17-18,  
SWITCHBACK® ASSAULT® '17-18,  
INDY® VOYAGEUR® 144 '17-18

INSTALLS/REMOVES  
EASILY IN SECONDS WITH  
LOCK & RIDE® TECHNOLOGY

REQUIRES FT2 REAR SEAT RACK  
(2883646)

### VOYAGEUR® 144 BRAKE LIGHT SUPPORT KIT

2883838  
REQUIRED TO INSTALL THE FT2 RACK ON  
MY17-20 600 VOYAGEUR® 144

### FT2 REAR SEAT RACK **★ TOP SELLER**

- Attaches in seconds with Lock & Ride® technology
- Made of powdercoated high-quality steel

2883646  
MY19-20 INDY® 129, MY20 INDY® 137, MY17-20 SBA,  
MY17-20 VOYAGEUR® 600 144, MY17-20 SWITCHBACK® SP



### FT2 UNDER RACK BAG **★ TOP SELLER**

- Easy access with weather-resistant zipper
- Compression-molded design provides rigidity
- Attaches directly to rack with all-weather Velcro®

2883714  
MY19-20 INDY® 129, MY20 INDY® 137, MY17-20 SBA,  
MY17-20 VOYAGEUR® 600 144, MY17-20 SWITCHBACK® SP



### PASSENGER GAUNTLETS

2883573  
ALL 1+1 SEAT

# POLARIS® **TITAN®**

LOCK & RIDE

## VERSA TOURING PASSENGER SEAT

- Attaches/removes in seconds with Lock & Ride® technology
- Heated version available
- Includes heated hand grips and connection for heated visor on full-face helmets
- Requires Versa Rear Cargo Rack (2882792)

Standard | 2882791 **★ TOP SELLER**

ALL TITAN®

Heated  | 2882801  
ALL TITAN®



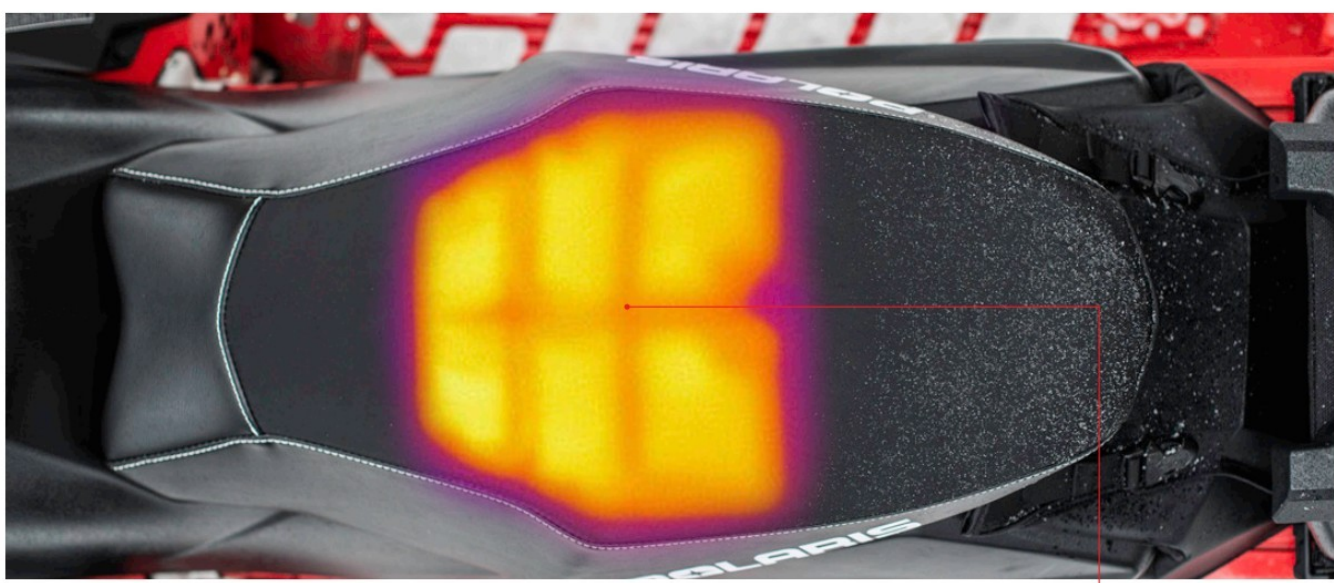

### HEATED SEAT **AXYS**

- Keep warm during the most demanding winter rides
- Features easy-to-use high/low/off switch for complete control
- Complete seat assembly with all mounting hardware and harness included

Black | **2882819**  
 MY15-20 RUSH®, MY15-20 SWITCHBACK®, MY17-20 SBA, MY18-20 SKS 146, MY17-20 144 RMK®, MY17-20 VOYAGEUR® 600 144, MY19-20 INDY® 129, MY20 INDY® 137

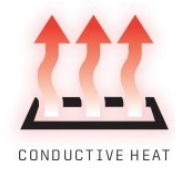

CONDUCTIVE HEAT

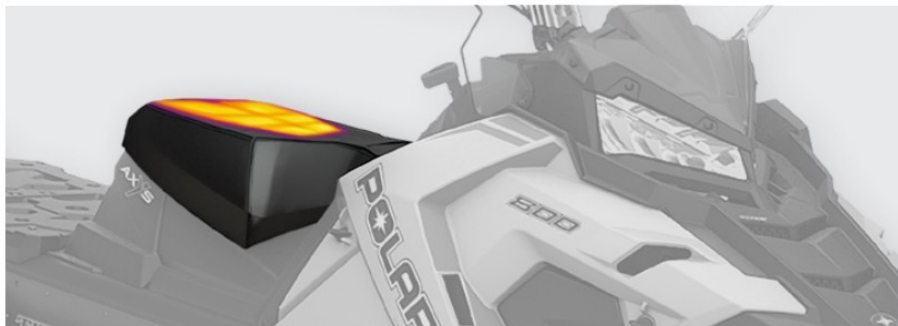

### POLARIS® TITAN® HEATED SEAT

- Keep warm during the most demanding winter rides
- Features easy-to-use high/low/off switch for complete control
- Complete seat assembly with all mounting hardware and harness included

Black | **2882747**  
 ALL TITAN®



### PASSENGER FOOTRESTS **AXYS**



- Add passenger comfort and security with passenger footrests
- Extruded aluminum design attaches directly to running board

Matte Black | **2882797**  
 ALL TITAN®  
 Raw | **2882817**  
 MY15-20 SWITCHBACK® 137  
 Raw | 129/144 | **2883571**  
 MY19-20 INDY® 129, MY20 INDY® 137, MY17-20 SBA



### COLOR SEAT SUPPORT **AXYS**

- Same construction as stock seat support for perfect fit
- Finish is color-matched to Polaris® graphics and resists chipping and wear

	Indy® Red	2881438-293
	Matte Black	2881438-458
	Lime Squeeze	2881438-630
	Orange Burst	2881438-647
	Velocity Blue	2881438-689
	Matte Gold Metallic	2881438-703
	Sky Blue	2881438-737

MY16-20 AXYS® RMK® 155-174





# BUMPERS

## FRONT BUMPERS

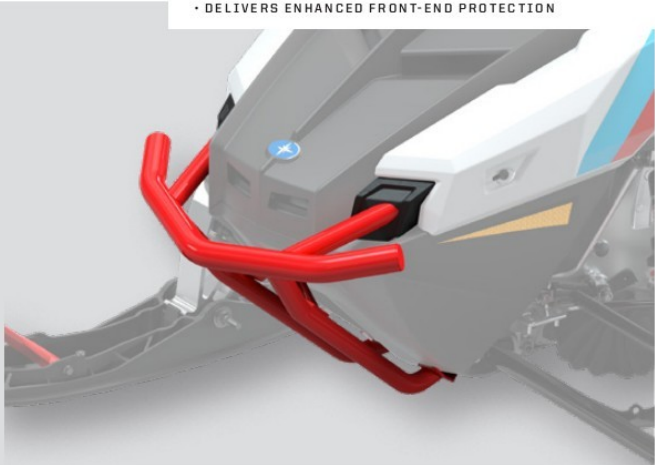
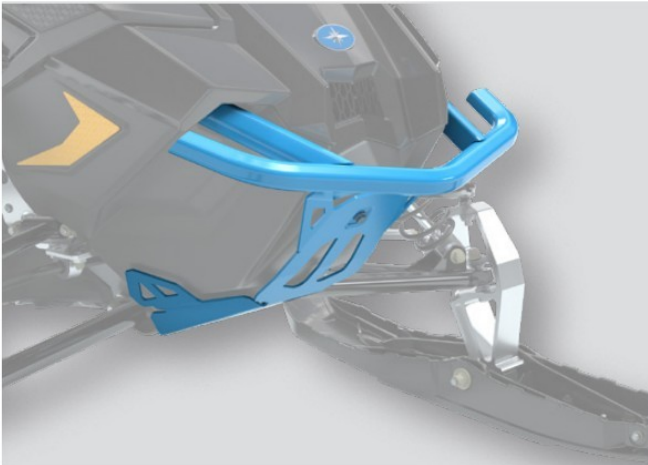

• DELIVERS ENHANCED FRONT-END PROTECTION

### MONARCH AXYS®

<input type="checkbox"/> Bright White	2883681-133
<input checked="" type="checkbox"/> Indy® Red	2883681-293
<input checked="" type="checkbox"/> Matte Black <b>★ TOP SELLER</b>	2883681-458
<input checked="" type="checkbox"/> Lime Squeeze <b>★ TOP SELLER</b>	2883681-630
<input type="checkbox"/> Orange Burst	2883681-647
<input type="checkbox"/> Velocity Blue	2883681-689
<input type="checkbox"/> Matte Gold Metallic	2883681-703
<input type="checkbox"/> Sky Blue	2883681-737

ALL AXYS®

### ULTIMATE PRO-RIDE®

<input checked="" type="checkbox"/> Aluminum	2879727
<input type="checkbox"/> Bright White	2879727-133
<input checked="" type="checkbox"/> Indy® Red <b>NEW</b>	2879727-293
<input checked="" type="checkbox"/> Matte Black	2879727-458

ALL PRO-RIDE®



Keep brush at bay and protect the front end of your TITAN® with the TITAN® HD Front Bumper. Features an integrated front-facing winch mount, black powder coating, and high-strength steel construction.



PROTECTION: MAXIMUM

### HD FRONT BUMPER

<input checked="" type="checkbox"/> Black	2882794
---	---------

ALL TITAN®

### TITAN® LIGHTBAR MOUNT

2882815
ALL TITAN® (REQUIRES HD FRONT BUMPER 2882794)



### TITAN® REAR BUMPER HANDLES

• Convenient rear grab points for your Titan®

2882803
ALL TITAN®





ADD A CUSTOM LOOK  
to the back of your sled

## REAR BUMPERS

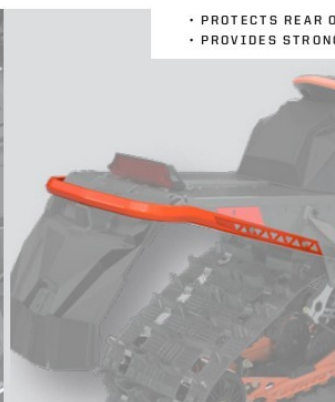
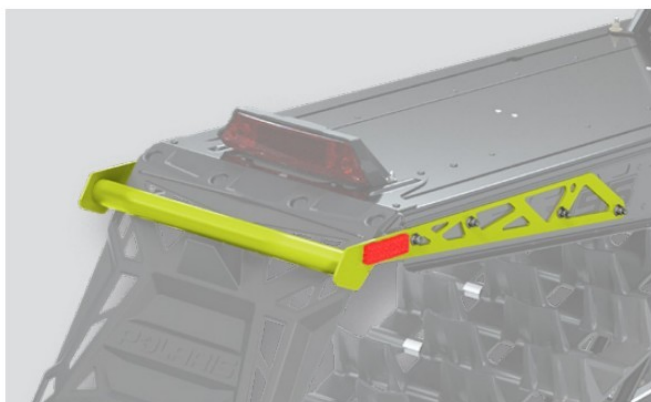

- PROTECTS REAR OF SNOWMOBILE
- PROVIDES STRONG GRAB BAR FOR SLED LIFTING

### EXTREME 144" // 155"/163" // 174"

COLORS	144"	155"/163"	174"
<input type="checkbox"/> Bright White	2881941-133	2880993-133	2881754-133
<input checked="" type="checkbox"/> Indy® Red	2881941-293	2880993-293	2881754-293
<input checked="" type="checkbox"/> Matte Black	2881941-458	2880993-458	2881754-458
<input checked="" type="checkbox"/> Lime Squeeze	2881941-630	2880993-630	2881754-630
<input checked="" type="checkbox"/> Orange Burst	2881941-647	2880993-647	2881754-647
<input checked="" type="checkbox"/> Velocity Blue	2881941-689	2880993-689	2881754-689
<input checked="" type="checkbox"/> Matte Gold Metallic	2881941-703	2880993-703	2881754-703
<input checked="" type="checkbox"/> Sky Blue	2881941-737	2880993-737	2881754-737

144" FITMENT: MY17-20 SWITCHBACK® ASSAULT®, MY17-20 SWITCHBACK® SP, MY17-20 600 VOYAGEUR®, MY17-20 RMK® 144.  
 155"/163" FITMENTS: ALL MY16-20 PRO-RMK®, RMK® ASSAULT®, 6 SKS.  
 174" FITMENT: MY17-20 PRO-RMK® 174

### INDY® XC ELITE PRO AXYS® **NEW**

<input checked="" type="checkbox"/> Gloss Black	2884257-067
<input checked="" type="checkbox"/> Bright White	2884257-133
<input checked="" type="checkbox"/> Indy® Red	2884257-293
<input checked="" type="checkbox"/> Lime Squeeze	2884257-630
<input checked="" type="checkbox"/> Orange Burst	2884257-647
<input checked="" type="checkbox"/> Sky Blue	2884257-737

ALL INDY® 129, INDY® 137, SBA 144

### ELITE PRO AXYS®

<input type="checkbox"/> Bright White	2882926-133
<input checked="" type="checkbox"/> Indy® Red	2882926-293
<input checked="" type="checkbox"/> Matte Black	2882926-458
<input checked="" type="checkbox"/> Lime Squeeze	2882926-630
<input checked="" type="checkbox"/> Orange Burst	2882926-647
<input checked="" type="checkbox"/> Velocity Blue	2882926-689
<input checked="" type="checkbox"/> Matte Gold Metallic	2882926-703
<input checked="" type="checkbox"/> Sky Blue	2882926-737

MY15-20 RUSH®, MY15-20 SWITCHBACK® 137





# WINDSHIELDS: AXYS®



Blend protection and style and find your ideal sightline



## LOW WINDSHIELD

AXYS®

Black / Gray	2880385
White / Black	2880386
Red / White	2880387
Blue / White	2881244
Orange / Black	2881245
White	2882062
Lime Squeeze	2882826

ALL AXYS®

## DEEP SNOW MID WINDSHIELD

AXYS®

Blue	2881053
White	2881054
Matte Black	2881055
Red	2881436
Gloss Black	2882058

ALL AXYS®

## FLATLAND MID WINDSHIELD

AXYS®

Clear	2880389
Gloss Black	2880390
White	2880391
Red	2880392

ALL AXYS® AND POLARIS® TITAN™

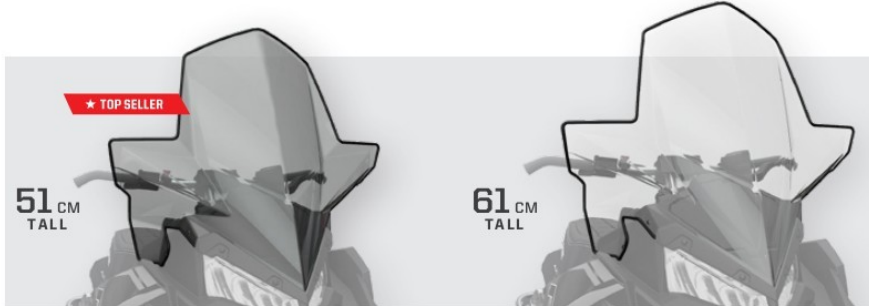

★ TOP SELLER

## TALL WINDSHIELD

AXYS®

Smoke	2880394
-------	---------

ALL AXYS®

## EXTRA TALL WINDSHIELD

AXYS®

Clear	2883078
-------	---------

ALL AXYS®



## FULL COVERAGE WINDSHIELD

Clear	2882796
-------	---------

ALL AXYS®



# WINDSHIELDS: PRO-RIDE®

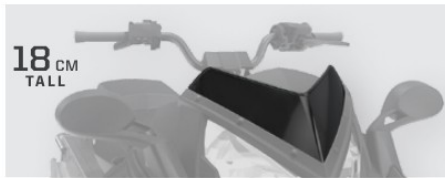

## LOW WINDSHIELD

PRO-RIDE®

Black	2878779
White	2879097

ALL PRO-RIDE®



## MID WINDSHIELD

PRO-RIDE®

Smoke	2877841
Matte Black	2879828
White Gloss	2879829

ALL PRO-RIDE®

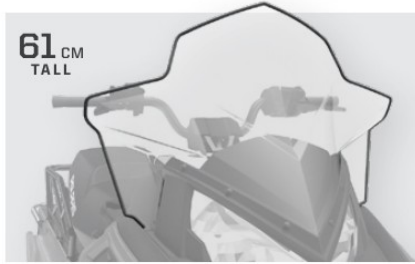

## WIDE WINDSHIELD

PRO-RIDE®

Clear	2878512
-------	---------

ALL PRO-RIDE®

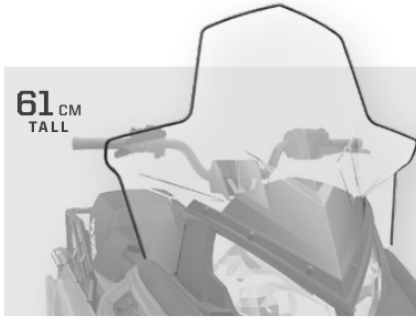

## EXTRA-WIDE TALL WINDSHIELD

PRO-RIDE®

Clear	2879156
-------	---------

ALL PRO-RIDE®



ACCESSORIES

STORAGE RACKS  
CARRIERS & HITCHES

SEATING, WINDSHIELDS  
& BUMPERS

ROUNTING BOARDS  
& SKID PLATES

RISE COMMAND™ PLD.D.  
HOOD PANELS & WIPERS

HANDLEBARS  
& ELECTRONICS

COVERS & TRAILERING

SKIS, SHOCKS & BENTS

TRACKS

FULL COVERAGE

EXTRA TALL

TALL

MID

DEEP SNOW MID

LOW

## FIND YOUR PERFECT SIGHTLINE

Blend protection and style with the windshield built just for the type of riding you do most.

### TALL

The choice when you want maximum wind protection. Perfect for riders who ride in colder conditions often.

### MID

The best of both worlds: a clean look for your sled that also offers wind protection for colder days.

### LOW

For a sleek, clean look on your sled. Does not affect vision in any way. Great for riders who stand up most of the time.





# RUNNING BOARDS



Give your foothold a customized look with factory-matched running board options



EXTREME 155"/163"



EXTREME 174"

## EXTREME 144"/146" // 155"/163" // 174" **AXYS**

- Design optimizes snow extrusion to prevent ice buildup for optimal rider control and performance
- Secure front and rear attachment with factory-bonded castings
- Removable and serviceable running board assemblies

COLORS	144"/146"	155"/163"	174"
<input type="checkbox"/> Bright White	2881965-133	2881041-133	2881952-133
<input checked="" type="checkbox"/> Indy® Red	2881965-293	2881041-293	2881952-293
<input checked="" type="checkbox"/> Matte Black	2881965-458	2881041-458	2881952-458
<input checked="" type="checkbox"/> Lime Squeeze	2881965-630	2881041-630	2881952-630
<input checked="" type="checkbox"/> Orange Burst	2881965-647	2881041-647	2881952-647
<input checked="" type="checkbox"/> Velocity Blue	2881965-689	2881041-689	2881952-689

144"/146" FITMENTS: MY17-20 SWITCHBACK® ASSAULT®, MY17-20 SWITCHBACK® SP, MY17-20 600 VOYAGEUR®, MY17-20 RMK® 144, MY18-20 SKS 146. 155"/163" FITMENTS: 155" 6 163" AXYS® PRO-RMK®, RMK® ASSAULT®, 6 SKS. 174" FITMENTS: MY17-20 PRO-RMK® 174

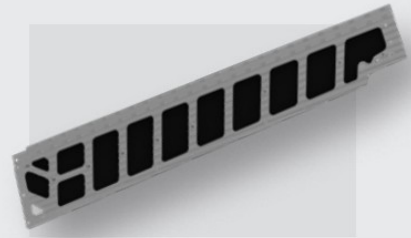

## RUNNING BOARD CLOSE-OUT PLATES

- Aids in water and slush protection when riding in wet conditions
- Premium polyethylene design delivers lightweight protection

2882810  
ALL TITAN®



## TAILLIGHT GUARD

- Protect the top housing of your taillight from stowed gear or accessories
- Rugged aluminum construction secures directly to the rear cargo platform

2882809  
ALL TITAN®, DOES NOT FIT WITH TITAN® CARGO BOX (2882793) OR TITAN® REAR RACK (2882792)





### KNEE PADS

PRO-RIDE®

2878195 | Set of Two  
ALL PRO-RIDE®



## SKID PLATES

- PROTECTS SUSPENSION AND BULKHEAD
- MADE OF STRONG 3/4" UHMW PLASTIC

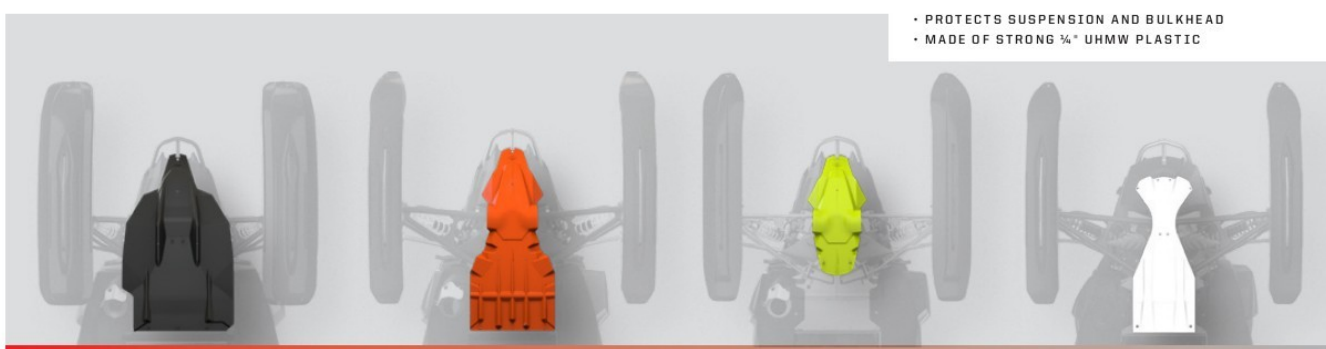

PROTECTION: MAXIMUM ————— MEDIUM ————— STANDARD

### HIGH COVERAGE

AXYS®

- Provides the greatest amount of underbelly protection
- Gives a completed and customized look
- Rugged and lightweight UHMW material
- Please note, this may hinder deep snow performance

Black 2882748-070

ALL AXYS® & TITAN®, NOT RECOMMENDED WITH RMK®

### ULTIMATE

AXYS®

- Enhances protection of belly pan and bulkhead
- Includes all mounting hardware

Black	★ TOP SELLER	2880383-070
Bright White		2880383-133
Indy® Red		2880383-293
Matte Black	★ TOP SELLER	2880383-458
Voodoo Blue		2880383-619
Orange Burst		2880383-647

ALL AXYS® & TITAN®

### EXTREME

AXYS®

- Extended length delivers extra protection for belly pan and bulkhead
- Includes all mounting hardware

Black	2880384-070
Bright White	2880384-133
Indy® Red	2880384-293
Voodoo Blue	2880384-619
Lime Squeeze	2880384-630
Orange Burst	2880384-647
Velocity Blue	2880384-689

ALL AXYS® & TITAN®

### STANDARD

PRO-RIDE®

- Adds color and custom style
- Includes all mounting hardware

Black	2878155-070
Bright White	2878155-133
Indy® Red	2878155-293

ALL PRO-RIDE®



**POLARIS**  
**RIDE COMMAND**  
**STAY CONNECTED**

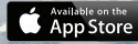

To download the RIDE COMMAND APP for free, text SNO1 to 82350

**SEAMLESSLY  
 ENHANCE YOUR  
 SNOWMOBILING  
 EXPERIENCE**

Pair your P.I.D.D. with the revolutionary Ride Command® app and enhance your snowmobiling experience by connecting with your friends and your sled. Ride Command®, when paired with a P.I.D.D., allows you to plan rides and coordinate with friends before, during, and after your ride. Also, get quick-glance access to critical snowmobile diagnostic info and GPS navigation. It enhances the features of your P.I.D.D. and allows you to get even more from your ride.

# P.I.D.D.

**POLARIS® INTERACTIVE  
 DIGITAL DISPLAY (P.I.D.D.)**

- Bright, easy-to-read 11 cm full-color LCD screen
- GPS Course Up or North Up option
- GPS Go-to function with distance on map screen
- Exporting capabilities for trip data from the display to USB drive
- TPS, RPM, and ground speed playback for snowmobile tuning, including clutch calibration
- Real-time gauge with speed, RPM, and average MPG
- Phone connectivity shows incoming calls, texts, battery life, and signal
- Toggle through display modes with handlebar control

**2881554** TOP SELLER  
 MY15-20 AXYS®, MY10-20 PRO-RIDE® (EXCLUDING 550 MODELS). MUST ORDER INSTALL KIT WITH DISPLAY. REQUIRED PARTS TO INSTALL FOR POLARIS® INTERACTIVE DIGITAL DISPLAY

**P.I.D.D. INSTALL KIT**

**AXYS** | 2880493  
 ALL AXYS® 600/800 (DOES NOT FIT TITAN®)

2883844  
 ALL 850 ENGINES & TITAN®

**PRO-RIDE** | 2880495  
 ALL PRO-RIDE® SNOWMOBILES (EXCLUDES 550)



**FURTHER ENHANCEMENTS WHEN PAIRED WITH RIDE COMMAND® APP INCLUDING GROUP RIDE FUNCTION AND LOCAL WEATHER INFORMATION**

## DON'T HAVE AN ELECTRIC START?

FOR A BETTER EXPERIENCE WITHOUT ELECTRIC START, INSTALL THE P.I.D.D. POWER UP KIT

- ADVANTAGES INCLUDE:**
- Maintain GPS lock when you start your sled back up (Without battery kit, satellite will need to relocate, which can take up to 30 seconds while moving)
  - Display will not shut down and reboot every time your sled is shut off
  - Display has ability to run while sled is turned off, which allows you to use the screen while stopped

**P.I.D.D. POWER UP KIT**

**2882200**  
 ALL AXYS® 600/800 (DOES NOT FIT TITAN®)

**2884303**  
 ALL 850 ENGINES

BATTERY SOLD SEPARATELY (4013045 OR E04989 PAGE 73)







# HOODS & PANELS



ACCESSORIES

STORAGE RACKS  
CARGO LUGS & HITCHES

SEATING, WINDSHIELDS  
& BUMPER

RUNNING BOARDS  
& SKID PLATES

RISE COMMAND™, P.T.O.D.  
HOOD PANELS & WINDAHS

HANDLEBARS  
& ELECTRONICS

COVERS & TRAILERING

SKIS, SHOCKS & KITS

TRACKS



## PAINTED HOOD

- Design a one-of-a-kind Polaris® AXYS® with a colored hood
- Includes all necessary sound and heat shielding
- Hood does not include headlight or decals

Indy® Red	2882131-293
White	2882131-599
Lime Squeeze	2882131-630
Orange Burst	2882131-647
Black Pearl	2882131-666
VelocityBlue	2882131-689
Matte Titanium MetallicSmooth	2882131-705

ALL AXYS® & TITAN®

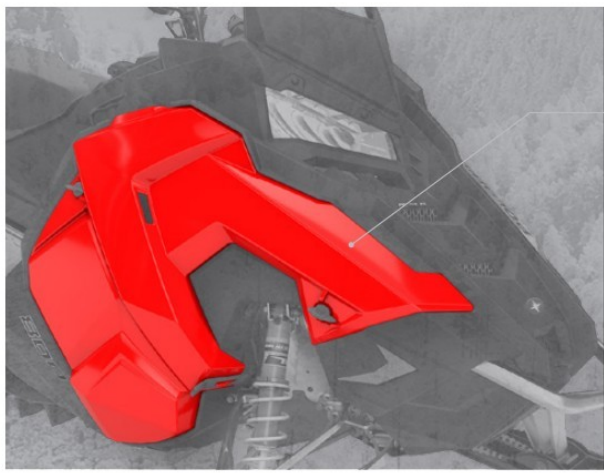

## SIDE PANELS

- Design a one-of-a-kind Polaris® AXYS® with colored side panels
- Panels sold individually and do not include decals

LEFT SIDE PANEL		RIGHT SIDE PANEL	
Indy® Red	5451230-293	Indy® Red	5451231-293
White	5451230-599	White	5451231-599
Orange Burst	5451230-647	Orange Burst	5451231-647
Black	5451230-666	Black	5451231-666
VelocityBlue	5451230-689	VelocityBlue	5451231-689

ALL AXYS® EXCEPT ALL TITAN®, DOES NOT INCLUDE QUARTER-TURNS (REQUIRES FOAM/FOIL KIT 2635483).





# HANDLEBARS

## PROTAPER® HANDLEBAR WITH HEATED GRIPS

- ProTaper® handlebar allows riders to customize their handlebar height for their riding style
- Handlebar hooks sold separately (1823339-070)

12.7 cm Rise | Black | **2881235**  
 15.2 cm Rise | Anodized Gray | **2881236**  
 17.7 cm Rise | Silver | **2881237**  
 ALL AXYS® RMK® WITH 600/800 ENGINE

12.7 cm Rise | Black | **2883835**  
 15.2 cm Rise | Anodized Gray | **2883836**  
 17.7 cm Rise | Silver | **2883837**  
 ALL AXYS® RMK® WITH 850 ENGINE



### HANDLEBAR ACCESSORIES



#### MOUNTAIN HOOP

**2882118**  
 ALL STRAIGHTBAR APPLICATIONS



#### ROX® ADJUSTABLE BAR RISER

**2881410**  
 ALL AXYS® STRAIGHTBAR APPLICATIONS  
 Increase handle bar height from 6.4 to 10.2 cm



#### HANDLEBAR HOOK

**2872482-070**  
 DOES NOT FIT PROTAPER® BARS



## HANDGUARDS



#### POLARIS® HANDGUARDS

- Durable, impact-resistant plastic
- Mounts required; sold separately

Red | **2879193**

Black | **2879192** ★ TOP SELLER

White | **2879194**  
 ALL SNOWMOBILES



#### XL HANDGUARDS

- Oversized for increased wind protection
- Durable, compression-molded design
- Mounts included

**2884258**  
 ALL AXYS® STRAIGHTBAR APPLICATIONS

#### REQUIRES A MOUNT

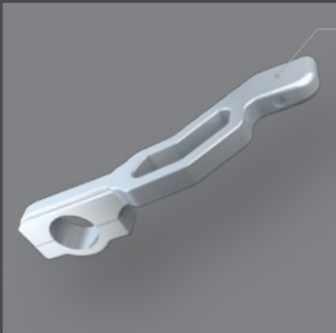

#### HANDGUARD MOUNTS ★ TOP SELLER

- Strong mounts ensure proper handguard installation
- Easy install: Mounts directly onto handlebar

**2880939**  
 ALL AXYS® STRAIGHTBAR APPLICATIONS

#### RMK® HANDGUARD MOUNTS

- Strong mounts ensure proper handguard installation
- Installs securely on any ProTaper® handlebar

**2881241-458**  
 ALL PROTAPER® RMK® BARS



## MIRRORS



★ TOP SELLER

#### MIRRORS

- Wide-angle view; non-fogging glass
- Folding design for use with cover
- Includes mounting hardware
- Sold as a pair

**2880292**  
 ALL AXYS®



#### HANDLEBAR MIRRORS

- Can be used with stock handlebar pad
- Sold as a pair

**2876297**  
 ALL PRO-RIDE®



★ TOP SELLER

#### HOOD MOUNT MIRRORS

- Wide-angle view; non-fogging glass
- Folding design for use with cover
- Includes mounting hardware
- Sold as a pair

**2877803**  
 ALL PRO-RIDE®



## KEY-OPERATED ELECTRIC START KIT

- The ultimate convenience feature you can add to your sled
- Easier to use and more consistent than pull starts
- Ideal for extreme cold conditions
- Battery required and not included

**2881243** ★ TOP SELLER  
600/800 AXYS® RMK® & SKS 155

**2880396**  
600/800 AXYS® RUSH®, SWITCHBACK®, SBA SKS 146 & INDY®

**2883931** ★ TOP SELLER  
ALL 850 PRO-RMK®

**2883849**  
ALL 850 RUSH®, SWITCHBACK®, SBA, SKS 146, & INDY®

**2879330**  
ALL PRO-RIDE®

**2879833**  
VOYAGEUR® 550, INDY® 550, 550 EVO, PRO-RIDE 550



## BATTERY (REQUIRED FOR ELECTRIC START KITS)

Sealed, Non-Spill | 4013045: YTX20 / E04999: ETX20  
ALL AXYS®, PRO-RIDE®



★ TOP SELLER

## TETHER SWITCH

- Shuts off vehicle if you're separated from it
- Easy to install
- Mounts directly on pod, connects to prewired harness

**2874379**  
ALL 550, 600, 800 ENGINES  
ALL AXYS®, PRO-RIDE® & TITAN®

**2883823**  
ALL 850 ENGINES



## 12 VOLT / RCA PLUGS

- 12V accessory plugs into 12-volt outlet, great for GPS or phone, dash mount
- RCA adapter allows you to plug in a heated face shield or vest
- RCA power plug includes all hardware required to add an RCA outlet

**12V** ★ TOP SELLER | **2878475**  
ALL AXYS®, PRO-RIDE® & TITAN®

RCA Power Plug | **2883824** ★ TOP SELLER  
ALL 850 ENGINES

RCA Adapter | **2878227**  
ALL SNOWMOBILES EQUIPPED WITH 12V OUTLET

RCA Power Plug (NOT SHOWN) ★ TOP SELLER  
**2878780**  
ALL 550, 600, 800 ENGINES  
ALL AXYS®, PRO-RIDE® & TITAN®



## GAUNTLETS



### DRIVER GAUNTLETS

**2883716**  
ALL AXYS® STRAIGHTBAR APPLICATIONS



### PASSENGER GAUNTLETS

**2883573**  
ALL FT2 & TITAN® PASSENGER SEATS





# COVERS



Only Polaris® offers a tailored solution for your sled with unmatched reliability and performance

## PREMIUM POLYESTER

- Polyester construction provides extremely durable protection from the elements, especially while trailering
- Fits full range of windshield heights
- Includes integrated straps and hardware
- Coated to repel water and resist UV degradation
- Tested over thousands of miles by Polaris®
- Redesigned stitching for more durability

PRO-RIDE  
AXYS

All AXYS® Full Tunnel 129, 137, 144 & 146	★ TOP SELLER	Convertible	2883568
UNDERCOVER		¾	2881981
PRO-RMK® / SKS		¾	2881042
RMK® ASSAULT®		¾	2881042
RUSH®		¾	2880431
SWITCHBACK®		¾	2880431
SWITCHBACK ADVENTURE®		¾	2880431
RUSH®		Full	2882223
SWITCHBACK®		Full	2882224
SWITCHBACK® WITH RACK / ADVENTURE®		Full	2882225
SWITCHBACK® 144	★ TOP SELLER	Full	2882133
PRO-RMK® 155 / SKS 146/155		Full	2882133
RMK® ASSAULT® 163/174		Full	2882134

## CANVAS

- 10 oz. canvas construction provides durable protection from the elements
- Fits full range of windshield heights
- Coated to repel water and resist UV degradation
- Form-fitting elastic cinch design
- Tested over thousands of miles by Polaris®
- Redesigned stitching for more durability

PRO-RIDE  
AXYS

ALL TITAN®	★ TOP SELLER	Convertible	2882800
RUSH® / SWITCHBACK® WITH SPORT RACK		Full	2882136
RUSH®		Full	2882135
SWITCHBACK® 137		Full	2882137
SWITCHBACK ADVENTURE® WITH RACK		Full	2882138
SWITCHBACK® ASSAULT® 144	★ TOP SELLER	Full	2881969
PRO-RMK® 155 / SKS 146/155	★ TOP SELLER	Full	2881969
RMK® 163/174	★ TOP SELLER	Full	2881980
INDY® 121 / INDY EVO®	★ TOP SELLER	Full	2878725
550 INDY® 144		Full	2879845
INDY® VOYAGEUR® 144		Full	2879845
550 INDY® ADVENTURE 144 - 155		Full	2879844
INDY® LX T		Full	2880515
INDY® VOYAGEUR® 144/155 WITH 2-UP SEAT		Full	2880515
INDY® VOYAGEUR® 155		Full	2880516



## UNDERCOVER

- Made to go under Polaris® snow covers to provide an additional level of protection
- Soft fabric helps to minimize cosmetic damage caused by chafing
- Easy to install and remove
- Works well as a dust cover when machine is stored inside
- The undercover is separate from the cover, which allows it to be kept clean by machine washing. We recommend using a washing machine bag to contain the elastic and hooks
- Air dry



## CONVERTIBLE COVERS

- Expandable zippered areas allow for multiple accessory configurations with a single cover
- Our most rugged snowmobile cover for the most demanding applications
- High-quality canvas fabric and form-fitting design is ideal for towing or storage





# CALIBER™ RAMP PRO

The industry's most innovative ramp design for snowmobiles, ATVs, UTVs, and golf carts.

Contact your local Polaris dealer for offers. Available in different models and sizes.

★ TOP SELLER

- 132 cm wide and 229 cm long
- 680 kg pound rating

2883005  
ALL SNOWMOBILES

ULTIMATE TRACTION AND GLIDE



FINGERS



INTEGRATED FEET

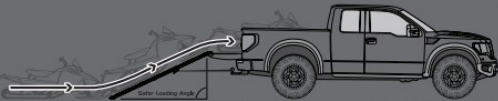

2.3 m = SAFER LOADING ANGLE



SELF-RETRACTING STRAP INCLUDED

ACCESSORIES

STORAGE RACKS  
CANNULAS & HITCHES

SEATING, WINDSHIELDS  
& BUMPERS

RUNNING BOARDS  
& SKID PLATES

RISE COMMAND™ P.L.O.D.  
HOOD PANELS & WIPERS

HANDLEBARS  
& ELECTRONICS

COVERS & TRAILERING

SKIS, SHOCKS & KITS

TRACKS

67



## CALIBER™ SLED WHEELS

- Large 12.7 cm wheels for easy steering/rolling
- Move your sled around the garage with ease

RED | 2883852 ★ TOP SELLER  
GRAY | 2883853  
ALL SNOWMOBILES

## WWW.SUPERCLAMP.NET

The #1 SNOWMOBILE & ATV TRAILER ACCESSORIES



### FRONT CLAMP

- Adjustable to fit all snowmobiles
- Rubber silicone pads protect and secure skis
- Integrates to all trailers
- Includes deck hook

2882961  
ALL SNOWMOBILES



SUPERCLAMP DECK HOOKS 2882963

### REAR CLAMP

- Composite construction with silicone rubber padding
- Tension adjustment knob to fit all snowmobiles
- Secures via rear suspension skid
- 30.5 cm Supertrac Kit included

2882962



SUPERCLAMP TRAC HOOK

2882965  
SUPERCLAMP TRAC

2882964



# SHOCKS

TRAIL



## WALKER EVANS® TRAIL PERFORMANCE SHOCKS

- External hi/lo ProDial compression damping adjustment
- Piggyback reservoir provides increased oil and nitrogen volumes for fade-free performance
- Velocity- and position-sensitive needle damping
- Ultra-progressive MCU bump stop
- 100% designed, engineered, and manufactured in the U.S.A.
- Fully rebuildable and revalveable

### IFS (EACH)

2881946

MY15-20 RUSH®, MY15-20 SWITCHBACK® 137, MY19-20 INDY® 129, MY17-20 SWITCHBACK® ASSAULT®, MY17-20 SWITCHBACK® SP

### FRONT TRACK

2881947

MY15-20 RUSH®, MY15-20 SWITCHBACK® 137

### REAR TRACK

2881948

MY15-20 RUSH®, MY15-20 SWITCHBACK® 137

CROSSOVER



## FOX® SWITCHBACK® SHOCKS

- Quick Switch 3 compression dial makes for quick adjustments for changing conditions
- Coil over air shock design
- 6061 aluminum body with anodized finish

### IFS (EACH)

2881411

MY15-20 RUSH®, MY15-20 SWITCHBACK® 137, MY19-20 INDY® 129, MY17-20 SWITCHBACK® ASSAULT®, MY17-20 SWITCHBACK® SP

### FRONT & REAR TRACK SHOCK SET

2881412

MY15-20 RUSH®, MY15-20 SWITCHBACK® 137

MOUNTAIN



## WALKER EVANS® CROSSOVER SHOCK

- Velocity- and position-sensitive needle damping
- 16-way compression adjuster to fine-tune ride through changing conditions
- Piggyback reservoir provides increased oil and nitrogen volumes for fade-free performance
- Progressive MCU bump stop

### IFS (EACH)

2881970

MY15-20 RUSH®, MY15-20 SWITCHBACK® 137, MY19-20 INDY® 129, MY17-20 SWITCHBACK® ASSAULT®, MY17-20 SWITCHBACK® SP

### FRONT TRACK

2881971

MY17-20 SWITCHBACK® ASSAULT®, MY17-20 SWITCHBACK® SP

### REAR TRACK

2881972

MY17-20 SWITCHBACK® ASSAULT®, MY17-20 SWITCHBACK® SP



## ÖHLINS® HIGH PERFORMANCE SHOCKS

- P-Type Shocks with springs included. Fully re-buildable.
- Adjustable compression and rebound adjuster.
- SWB shocks are updated for 2019 models.
- High

\*ÖHLINS SHOCKS FOR TITAN IS AVAILABLE. CONTACT YOUR NEAREST DEALER (SWB ASSAULT, NO SPRING INCLUDED)

PB610 | FRONT PRO RMK 36" (PAIR), Q-ADJUST 19-  
PB607 | FRONT RMK/SKS 17-19 (PAIR), 800 SKS 146" 19-  
PB608 | CENTER RMK/SKS 17-20  
MN011 | CENTER 36PC, RMK KHAOS 20-  
PB609 | REAR RMK/SKS 17-20  
PB614 | FRONT SWB ASSAULT (PAIR) 17-20  
PB615 | CENTER SWB ASSAULT 17-20 | SKS 146" 19-  
PB616 | REAR SWB ASSAULT 17-20, SKS 146" (36) 19-



## WALKER EVANS® AXYS® DEEP SNOW PREMIUM SHOCK

- 16-way compression adjuster to fine-tune ride through changing conditions
- Lightweight 6061 T6 extruded aluminum alloy design
- Piggyback reservoir provides increased oil and nitrogen volumes for fade-free performance
- Front track shock features an internal floating piston monotube for consistent, fade-free performance
- 100% designed, engineered, and manufactured in the U.S.A.
- Fully rebuildable and revalveable

### IFS (NEED TWO)

2881058

INCLUDES MOUNTING HARDWARE, DOES NOT INCLUDE COIL OVER SPRING

MY16-19 AXYS® RMK® 6 SKS 155-174

### REAR TRACK

2881059

INCLUDES MOUNTING HARDWARE AND COIL OVER SPRING

MY16-19 AXYS® RMK® 155-174



## RMK® SLS SUSPENSION SPRINGS

- Lighter than titanium
- 1.36 kg weight reduction over stock springs
- Increased performance over stock springs

### FRONT IFS SHOCK SPRINGS

2883682-458

ALL MY16-20 PRO-RMK®

### TRACK SHOCK SPRINGS

2883715-458

ALL AXYS® PRO-RMK®



## EVOLution KITS

- Comes with everything you need to evolve your INDY EVO™ as the rider's skill increases
- Includes tie rods, control arms, spindles, shocks, and more!

### RMK® INDY EVO™ UPGRADE KIT

2884251

ALL RMK®, INDY EVO™

### INDY EVO™ UPGRADE KIT

2883939

ALL INDY EVO™



## RMK® REACT FRONT SUSPENSION KIT 36"

- Comes with everything you need to convert your 99cm wide front AXYS Pro-RMK to a 91.4 cm wide front end
- Includes shocks, upper & lower control arms, tie rods, sway bar, and all hardware

2883686-309

ALL MY16-MY20 PRO-RMK®

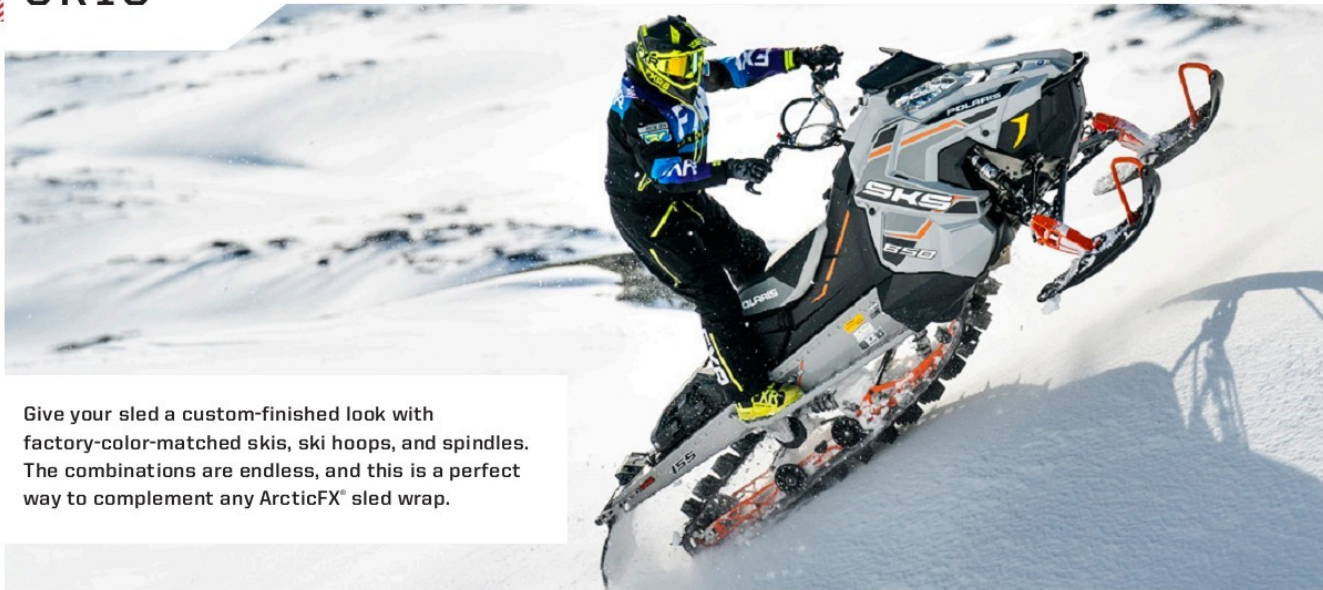

Give your sled a custom-finished look with factory-color-matched skis, ski hoops, and spindles. The combinations are endless, and this is a perfect way to complement any ArcticFX® sled wrap.



## MOUNTAIN

### GRIPPER SKI

AXYS® PRO-RIDE™

- Deep, 3.8 cm keel provides positive steering in deep, loose mountain snow
- Wide, 17 cm ski delivers increased flotation
- Top traction surface for boot stepping on ski
- Includes black ski toe and hardware; carbide skags required (sold separately; see chart)
- Sold individually

Black	2877679-070
Indy® Red	2877679-293
White	2877679-570

ALL AXYS®, ALL PRO-RIDE®

## UTILITY

### PRO-FLOAT SKI

AXYS® PRO-RIDE™

- Adapted, 24 cm wide Pro-Steer ski design provides 45% more flotation for off-trail deep snow performance
- Includes black ski toe
- Sold individually

Black	2880482
-------	---------

ALL AXYS® & PRO-RIDE®

## TRAIL

### PRO-STEER SKI

AXYS® PRO-RIDE™

- Engineered keel design and shortened skag perfect for the trail
- Supportive ribs for torsional stiffness
- No-slip traction atop ski
- Alternate ski stop may be required
- Includes black ski toe and hardware
- Sold individually

Black	2879152-070
Bright White	2879152-133
Indy® Red	2879152-293

ALL AXYS®, ALL PRO-RIDE®



### POLARIS® SKI HOOPS

- Adds custom style
- Reliable high-test tie down; secure sleds quickly and confidently

ALL POLARIS® SKIS

Black	2876062-070
Bright White	2876062-133
Indy® Red	2876062-293
Lime Squeeze	2876062-630
Orange Burst	2876062-647
Velocity Blue	2876062-689

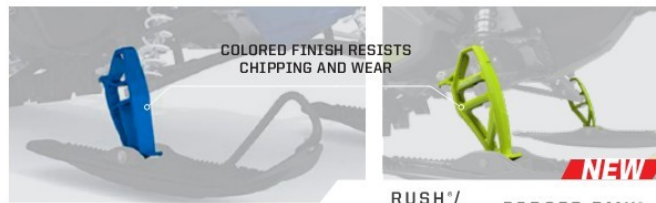

COLORED FINISH RESISTS CHIPPING AND WEAR

### SPINDLES

- Strong, lightweight aluminum construction with same tolerances as stock spindles
- Colored finish resists chipping and wear
- Exact replacement for stock RMK® spindles
- Color-matched spindles add a custom look to snowmobile

Gloss Black	N/A	2884205-067
Bright White	N/A	2884205-133
Indy® Red	2881409-293	2884205-293
Matte Black	2881409-458	N/A
Lime Squeeze	2881409-630	2884205-630
Orange Burst	2881409-647	2884205-647
Velocity Blue	2881409-689	N/A
Sky Blue	N/A	2884205-737

RUSH®/SWITCHBACK® FITMENT: MY15-20 RUSH® & SWITCHBACK®, MY17-20 SWITCHBACK® ASSAULT®, ALL TITAN®  
FORGED RMK® FITMENT: ALL AXYS® PRO-RMK®



# THE 4 KEYS TO TRACK SELECTION

## LENGTH

The inside circumference of the track is calculated as the drive pitch multiplied by the number of track segments. It must be correct to the nearest inch for proper fit without additional modifications to the skid frame.



## DRIVE PITCH

The drive cog center distance around the circumference of the cogs on the drive axle. It must match the existing track or the drive cogs must be changed.

- 2.52" drive pitch primarily machines manufactured before 2007
- 2.86" drive pitch especially on recent models manufactured after 2007
- 3" and new 3.5" drive pitch for lowest weight on select mountain sleds

## WIDTH

The measurement across the track governed by the width of the tunnel.

## LUG HEIGHT

The distance lugs extend above the track surface.

- Trail: 1" - <1.5"
- On/Off Trail: 1.5" - <2"
- Deep Snow: 2" and greater

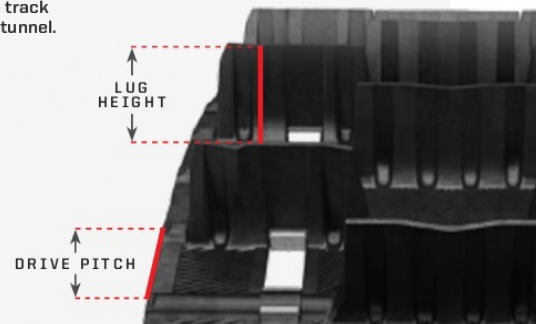

## TRAIL



**ICE STORM 150**



- Two-height lug design offers deep snow flotation with handlebar-gripping acceleration
- Factory pre-studded for improved traction and control on icy conditions
- 1.25" outer lugs and 1.5" cup-shaped center lugs provide power and traction on packed trails and turns

LENGTH	PITCH	LUG HEIGHT	
120"	2.86"	1.25"	2839388
129"	2.86"	1.25"	2839389
137"	2.86"	1.25"	2839390
146"	2.86"	1.25"	2839391

**HURRICANE**



- Designed based on mountain tracks, it provides off-trail performance in deep snow while maintaining on-trail agility
- 1.75" cupped profile design provides unparalleled grip in the backcountry
- 1.75" tall lug profile design reduces vibration, applying more power to the ground

LENGTH	PITCH	LUG HEIGHT	
120"	2.86"	1.75"	2839400
129"	2.86"	1.75"	2839401
137"	2.86"	1.75"	2839402
146"	2.86"	1.75"	2839403

**COBRA**



- Cupped lugs for superior acceleration and braking in loose, soft snow conditions
- Flexible lug design for superior off-trail performance

LENGTH	PITCH	LUG HEIGHT	
120"	2.86"	1.352"	2839284
121"	2.52"	1.352"	2839052
129"	2.86"	1.352"	2839235
136"	2.52"	1.352"	2839061
137"	2.86"	1.352"	2839307
137"	2.86"	1.352"	5413661
144"	2.52"	1.352"	2839107
144"	2.86"	2.52"	5414013
144"	2.86"	1.6"	5416162
155"	2.86"	1.5"	5415826
155"	2.86"	1.8"	5416020

**STORM 150**



- 1.25" outer lugs provide power through the tightest turns with ease, maintaining momentum and rider control
- 1.5" cup-shaped center lugs provide deep snow flotation, and gut-wrenching acceleration on packed trails
- Optimized support columns provide the right balance of lug rigidity and flex for performance across the entire power band

LENGTH	PITCH	LUG HEIGHT	
120"	2.86"	1.25"/1.5"	2839368
129"	2.86"	1.25"/1.5"	2839369
137"	2.86"	1.25"/1.5"	2839370
146"	2.86"	1.25"/1.5"	2839371

## MOUNTAIN



**SERIES 7**



- Polaris® exclusive
- Ideal track to provide lift in the deepest, softest snow conditions
- Features a new lightweight single-ply design optimized for weight and powder snow performance

LENGTH	PITCH	LUG HEIGHT	
155"	3"	3"	5415393
163"	3"	3"	5415394
174"	3"	3"	5415786

**SERIES 6**



- Outstanding traction and control in deep snow
- Lugs provide tremendous flotation and great performance
- 2.6" lugs provide outstanding traction in all deep snow conditions
- Design provides outstanding flotation and control

LENGTH	PITCH	LUG HEIGHT	
155"	2.86"	2.6"	5415391

**SERIES 5.1**



- Industry-leading deep powder track; for BT drive sprockets, 2.86" pitch
- Optimized lug pattern producing 19% more forward lug contact compared to our Series 5.0 track
- Soft and flexible tips for superior performance in deep snow

LENGTH	PITCH	LUG HEIGHT	
155"	2.86"	2.4"	5413622
163"	2.86"	2.4"	5413621

**PEAK 2.25**



- Angular lugs bite and funnel snow under the snowmobile for outstanding flotation
- Features soft lugs for powder snow and hard lugs for heavy/wet snow
- Outer lug bars deliver better lateral control for improved handling

LENGTH	PITCH	LUG HEIGHT	
155"	2.86"	2.25"	5415002

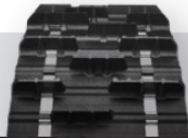

**BACKCOUNTRY**

ON TRAIL OFF TRAIL

- Arched lug design with staggered, snocross-inspired pattern for excellent soft-snow traction

LENGTH	PITCH	LUG HEIGHT	
120"	2.52"	1.75"	5414894
121"	2.52"	1.75"	2839140
121"	2.52"	1.75"	5415097
136"	2.52"	1.75"	2839142
136"	2.52"	1.75"	5414378
137"	2.86"	1.75"	5414895
144"	2.52"	1.75"	2839143
144"	2.52"	1.75"	5415096



**COBRA 1.6**

ON TRAIL OFF TRAIL

- Cupped lugs for superior acceleration and braking in loose, soft snow conditions
- Flexible lug design for superior off-trail performance
- Select lugs are more rigid for traction on hard-packed snow

LENGTH	PITCH	LUG HEIGHT	
120"	2.86"	1.6"	2839291
120"	2.86"	1.6"	5414902
129"	2.86"	1.6"	2839292
137"	2.86"	1.6"	2839264
155"	2.86"	1.6"	5414902

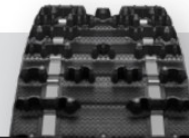

**ICE COBRA 1.6**

ON TRAIL OFF TRAIL

- Cupped lugs for superior acceleration and braking in loose, soft snow conditions
- Flexible lug design for superior off-trail performance
- Factory pre-studded with 1.6" lugs for excellent all-round performance, especially on ungroomed trails

LENGTH	PITCH	LUG HEIGHT	
120"	2.86"	1.6"	2839244
137"	2.86"	1.6"	2839246
155"	2.86"	1.6"	2839273

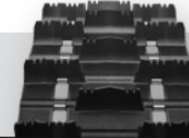

**CHALLENGER**

ON TRAIL OFF TRAIL

LENGTH	PITCH	LUG HEIGHT	
136"	2.52"	2"	2839797
137"	2.86"	2"	2839186
144"	2.52"	2"	2839875
146"	2.86"	2.5"	2839145
151"	2.52"	2"	2839876
153"	3"	2.5"	2839174
154"	2.86"	2.5"	2839104
156"	3"	3.2"	2839320
162"	3"	3.2"	2839175
162"	3"	2.5"	2839319
163"	2.86"	2.5"	2839105



**ICE ATTAK XT**

ON TRAIL OFF TRAIL

- Factory pre-studded for improved traction and control
- Designed to provide even better ice performance than the ICE Ripper XT
- 1.22" lug height provides better handling and stability
- Optimized rubber compound for superior traction on groomed trail

LENGTH	PITCH	LUG HEIGHT	
120"	2.86"	1.22"	2839190
121"	2.52"	1.22"	2839200
128"	2.52"	1.22"	2839201
129"	2.86"	1.22"	2839236
136"	2.86"	1.22"	2839202
137"	2.86"	1.22"	2839191
144"	2.52"	1.22"	2839203



**RIPSAW**

ON TRAIL OFF TRAIL

- Rigid lugs provide superior handling, acceleration, and braking on groomed trails
- Narrow lug base for reduced rolling resistance and maximum top speed
- Angled profiles for aggressive forward and lateral bite

LENGTH	PITCH	LUG HEIGHT	
120"	2.86"	1.25"	2839149
121"	2.52"	1.25"	2839146
121"	2.52"	1.25"	2839968
128"	2.52"	1.25"	2839001
128"	2.52"	1.25"	2839215
136"	2.52"	1.25"	2839969
136"	2.52"	1.5"	5413543
137"	2.86"	1"	2839234
155"	2.86"	1.375"	5416227



**RIPSAW 2**

ON TRAIL OFF TRAIL

- Tapered outside lug edges for less side bite when cornering
- Sharp angled lugs for excellent bite on hard-pack snow
- Cupped center and full outer lugs for traction on loose, less-compacted snow

LENGTH	PITCH	LUG HEIGHT	
120"	2.86"	1.25"	2839149
120"	2.86"	1.25"	2839209
120"	2.86"	1.5"	2839304
120"	2.86"	1.25"	5414653
121"	2.52"	1.25"	2839214
129"	2.86"	1.5"	2839305
136"	2.52"	1.25"	2839216
137"	2.86"	1.25"	2839223
137"	2.86"	1.5"	2839306
137"	2.86"	1.25"	5414654



**CONQUER 280**

ON TRAIL OFF TRAIL

- Lightweight construction
- 2.8" alternating single-angled lugs push performance in all-season riding conditions

LENGTH	PITCH	LUG HEIGHT	
153"	3"	2.8"	2839337
156"	3"	2.8"	2839336
162"	3"	2.8"	2839335
174"	3"	2.8"	2839334



**SERIES 5.2**

ON TRAIL OFF TRAIL

- Modeled after the modified Series 5.1 track used by Polaris® hillclimb racers
- Provides great traction both on and off trail
- Maintains excellent durability
- Optimized lug pattern for more forward lug contact

LENGTH	PITCH	LUG HEIGHT	
146"	2.86"	2.25"	5416498

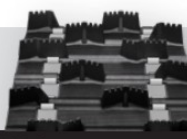

**SERIES 4**

ON TRAIL OFF TRAIL

- The standard in 2" deep snow tracks; for 9T drive sprockets, 2.52" pitch
- Equal parts versatility and durability
- Stiff lug base for long wear and hard-pack performance
- Soft and flexible tips for superior performance in deep snow

LENGTH	PITCH	LUG HEIGHT	
144"	2.52"	2"	5413073
144"	2.52"	2"	5415692

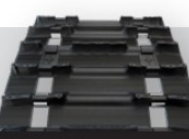

**SHOCK WAVE**

ON TRAIL OFF TRAIL

- Designed for hard-working, utility applications
- Able to handle heavy workloads in deep-snow, off-trail environments
- Tackles on-trail, hardpacked applications, too
- 1" lug height with 2.52" pitch

LENGTH	PITCH	LUG HEIGHT	
156"	2.52"	1"	5414453

**COMPETITION TRACK**

ON TRAIL OFF TRAIL

- Customized for snocross competition
- Developed for, and tested by, top Polaris® racers

LENGTH	PITCH	LUG HEIGHT	
155"	2.86"	2.1"	2877304

**YOUTH 120**

ON TRAIL OFF TRAIL

- Replacement track for the Polaris® 120 INDY®

LENGTH	PITCH	LUG HEIGHT	
68"	2.55"	.71"	5411751



# FOR THE LIFE OF YOUR RIDE

## DRIVE BELTS

Polaris Engineered® belts deliver unmatched performance for your snowmobile. Developed and tested on all our engines for all environments and conditions. Check your belt for delamination, hour glassing and glazing.

### BREAK-IN PERIOD

The break-in period for a new belt is . During this time, vary at moderate speeds while avoiding wide open throttle.



## EXIDE BATTERY CHARGER 220V

• Battery charger EXIDE, for LEAD/AGM 12V Batteries 4Ah to 150Ah.

**E261910**  
EXIDE BATTERY CHARGER 12V-4A, FITS BATTERIES UP TO 85AH

**E261920**  
EXIDE BATTERY CHARGER 12V-7A, FITS BATTERIES UP TO 150AH

## SPARK PLUGS

Spark plugs perform optimally with a sharp edge on the electrode for electrons to discharge from. When the edge starts to round, you should change the spark plug, about once per year.

## BATTERIES

Never leave a battery unattended during the storage season. To ensure your battery maintains its level of charge when unused for extended periods of time or during freezing weather, the battery should be connected to a BatteryMINDER®. Be sure to check for corrosion from the terminals to the ends of the cables.

## CARBIDES

Worn skis, skags or carbides will adversely affect handling. Inspect your carbides for bends in the host bar (which can cause wandering), sharp edges, chips or cracks (which cause darting), and blunt/square edges that may cause catch hazards. Replace your carbides when you detect any of these conditions.

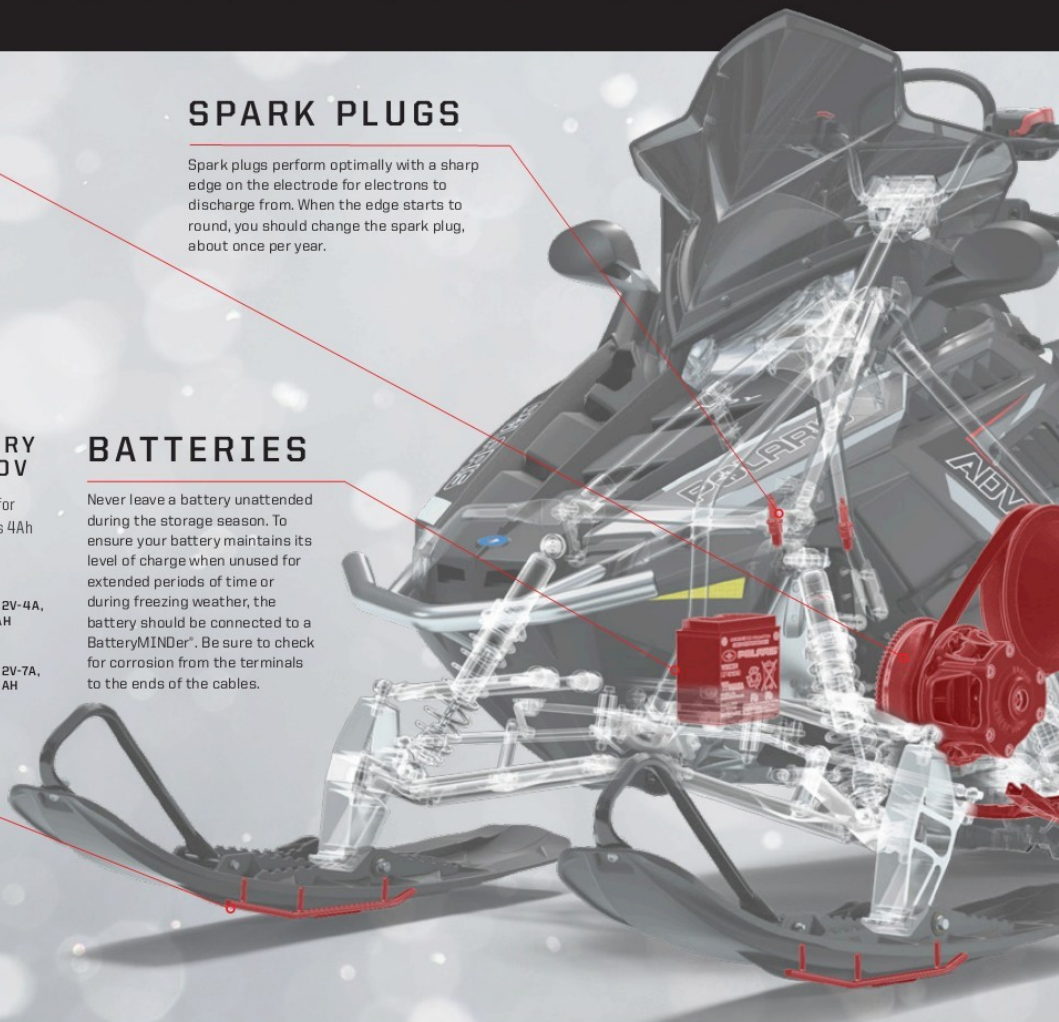

BELT COMPOUND & CONSTRUCTION NOTES	BELT WIDTH*	OUTER CIRCUMFERENCE*	PART NO.
<b>AXYS® (RUSH®, SWITCHBACK®, SWITCHBACK ADVENTURE®, SWITCHBACK® ASSAULT®, VOYAGEUR®, TITAN® &amp; INDY® 129)</b>			
HIGH MODULUS CHLOROPRENE BELT	1.46" (37.10mm)	45.16"	3211215 (850cc)
PBO BELT	1.46" (37.10mm)	45.16"	3211177 (800cc)
PBO BELT	1.46" (37.10mm)	45.16"	3211165 (600cc)
<b>AXYS® (PRO-RMK®, RMK® ASSAULT®, SKS)</b>			
HIGH MODULUS CHLOROPRENE BELT	1.46" (37.10mm)	46.77"	3211216 (850 cc)
PBO BELT	1.46" (37.10mm)	46.77"	3211183 (800cc)
PBO BELT	1.46" (37.10mm)	46.77"	3211115 (600cc)
<b>PRO-RIDE® (RUSH®, SWITCHBACK®, SWITCHBACK® ASSAULT®, INDY®, VOYAGEUR®, PRO-RMK®, RMK®, RMK® ASSAULT®)</b>			
PBO BELT	1.46" (37.10mm)	46.77"	3211115
KEVLAR® BELT	1.46" (37.10mm)	46.77"	3211122
KEVLAR® BELT	1.32" (33.53mm)	43.23"	3211174 (550cc)
STANDARD BELT	1.29" (32.77mm)	42.48"	3211154 (550cc)

\*Belt dimensions are given in nominal dimensions. There is a +/- variance for all critical dimensions. Clutch setup must be inspected when a new belt is installed and should be adjusted if necessary. The drive belt is an important component in the CVT system. In order to achieve maximum efficiency from the converter, drive belt deflection (tension), clutch offset, and alignment must be adjusted properly. See your Service Manual for further details on drive belt measurement inspection.

## POLARIS ENGINEERED™ DRIVE BELTS

### OUR INVESTMENT

- 32,187 kilometers of field testing
- Thousands of dyno hours
- 18+ months of development (3,000+ design hours) per belt
- 1200+ vehicle validation hours
- Collaboration with powertrain & clutch engineers

### YOUR ADVANTAGE

- No clutch recalibration
- Less wear & tear due to heat
- Ensure maximum performance of your vehicle
- More time out riding, less time wrenching

Maintenance is the key to keeping your Polaris® snowmobile performing at its peak. Items like belts, lubricants, and batteries represent only a few of these critical items engineered specifically by Polaris.

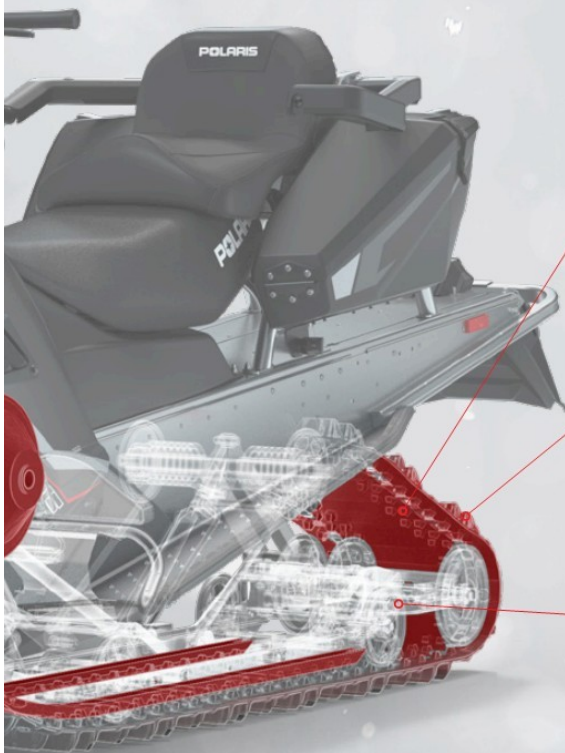

## TRACKS

Tracks are your key connection to the snow. Through use, they can accrue damage and wear out. Tracks should be checked regularly for weathering and dry-rotting and replaced immediately if damage is found.

## STUDS

Studs can bend, break, or pull through a track with extended, hard riding. Inspect your tracks regularly and replace studs as they wear down. If the track is torn around the stud hole, the track may need replacing.

## RAIL SLIDERS

Rail sliders wear out over time in normal riding conditions. Check the wear line on your rail to see if it needs replacing. They should typically be replaced once a year.

## MAINTENANCE



### BATTERIES

4013045 - YTX20CH YASA  
ED4999 - ETX20 EXIDE



### SPARK PLUGS

Engineered for your Polaris® sled  
NGK | 3022082  
Champion | 3070190

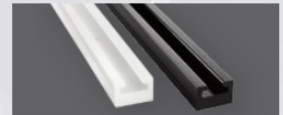

### SLIDERS

5521632                      5521633-309  
5521633-070                5522144-070

Contact your local Polaris dealer for correct sliders for your sled.

**TIPS:** Operating the vehicle immediately after cold starting could cause engine damage. Allow the engine to warm up for several minutes before operating the vehicle. If cold drive away is attempted, the engine RPM may stumble slightly to protect the engine.

# MAINTENANCE SCHEDULE

CHECK YOUR OWNER'S MANUAL FOR ADDITIONAL RECOMMENDED SERVICE ITEMS AND VEHICLE-SPECIFIC TIMING

## PRE-SEASON

**ENGINE OIL:**  
FILL TO RECOMMENDED LEVEL

**GENERAL LUBRICATION:**  
ALL FITTINGS, PIVOTS, CABLES, ETC.

**CHECK FOR WEAR:**  
TEST, CLEAN & CHECK FLUID LEVELS  
SPARK PLUGS, TRACK, SLIDER, DRIVE BELT & CARBIDES

500 MI (800 KM)

## IN-SEASON

**ENGINE OIL:**  
FILL TO RECOMMENDED LEVEL

**DRIVE BELT:**  
INSPECT & ADJUST  
FOLLOW BREAK-IN PROCEDURE AFTER INSTALLATION

**TRANSMISSION FLUID:**  
CHANGE

2000 MI (3200 KM)

## IN-SEASON

**ENGINE OIL:**  
FILL TO RECOMMENDED LEVEL

**CHECK FOR WEAR:**  
TEST, CLEAN & CHECK FLUID LEVELS  
SPARK PLUGS, TRACK, SLIDER, DRIVE BELT & CARBIDES

**DRIVE BELT:**  
INSPECT & ADJUST  
REPLACE AS NEEDED

## END OF SEASON

**DRIVE BELT:**  
REMOVE  
CONSULT OWNER'S MANUAL

**FUEL:**  
ADD FUEL STABILIZER

**TRACK:**  
INSPECT  
REDUCE TENSION DURING STORAGE

**BATTERY:**  
REMOVE





## OIL FOR EVERY SLED, PROVEN IN THE TOUGHEST RACE.

When you're flying across 3,219 kilometers of Alaskan tundra, racing riders and the bitter winter wind to seize your immortal moment, you need equipment you can count on. Iron Dog® snowmobile riders count on Polaris Engineered Oils & Lubricants™ to withstand sub-zero temperatures, mountain ranges, and rock hard wind drifts at high speed over a grueling 35 hours.

They know Polaris® Engineers rigorously test every fluid before it earns the Polaris Engineered Lubricants™ badge and a spot on the shelf. So inside and out, their sled will be just as strong as their will to win. Whether you're racing across the Alaskan wilderness or just casually riding on a trail, you can be confident there's no better oil for your sled than Polaris Engineered Oils & Lubricants™.

### VES

Low-odor, low-smoke oil formulation designed to improve exhaust valve performance. VES offers maximum engine protection.

#### OUR FORMULATION

- Synthetic Performance formula
- Proprietary anti-wear, corrosion and detergency additive package
- Retains film on critical engine parts after hot shutdown

#### YOUR ADVANTAGE

- Engineering approved for use across all snow engine platforms
- Cleaner burning resulting in extended life of cylinders, pistons, rings & bearings
- Protects engine during periods of non-use or storage
- Reduces pull effort by leaving components lubricated

### NEW

### VES EXTREME

Engineered, formulated and tested to easily handle the high demands of today's high-performance Polaris® snowmobile engines.

#### OUR FORMULATION

- Full synthetic, 100% PAO and Ester formula
- Highest engine film strength and lubricity protection
- Optimized mixture of heavy and light viscosity base oils and solvents
- Proprietary anti-wear, corrosion and detergency additive package

#### YOUR ADVANTAGE

- Best engine wear protection available for 2-cycle snowmobile engines on the market
- Maintains like-new HP performance throughout engine lifecycle
- Enhanced oil to ensure pins, bearings and all metal-on-metal components are protected
- Highest detergency available for ring lands, undercrown and exhaust valves

1L  
502493

25L  
502515

20L  
502517

4L  
502514

60L  
502516

4L  
502691  
VES EXTREME, ONLY  
AVAILABLE IN 4 LITERS

## OIL DEVELOPMENT

POLARIS INVESTS IN EACH OIL AT AND ABOVE THESE LEVELS.

**12** DEDICATED  
TEAM MEMBERS

FOCUSED ON  
POLARIS OIL

**18+**  
MONTHS

DEVELOPMENT  
& TESTING



# POLARIS®

ENGINEERED LUBRICANTS

## FOR THE LIFE OF YOUR RIDE, ONLY THE BEST WILL DO.

In the continued pursuit of creating the best oil on snow, we invest in rigorous testing to ensure our oil delivers unrivaled consistency and performance. The result are Polaris Engineered Lubricants™ that are tested and perfected to deliver excellent total engine protection for the life of your ride.

*Oil and cleaners featured are for EU distribution only. For other availability, contact your local dealer.*



### WHAT COUNTS IN OIL TESTING:

1. Does it protect the engine at low temperatures?
2. Does it protect the engine from high heat wear?
3. Does it keep the engine clean?

### PISTON CHECKPOINTS

**PISTON DOME:** Is it clean? Clean burning oil and our proprietary detergency system prevents carbon buildup and hot spots, which extends piston life and maintains optimal run quality.

**PISTON RINGS AND RING LANDS:** Are they free of carbon deposits and soot? This is important to preserve ring seal and maximum power output.

**PISTON PINS AND NEEDLE BEARINGS:** Proper viscosity and lubricity, film strength and our proprietary additives provide exceptional protection and heat control, maintaining proper pin and bearing tolerances and performance.

**PISTON SKIRT:** Is the Grafal coating scratched or visibly damaged? Harsh contact between the cylinder and piston due to insufficient lubrication would eventually result in engine failure.



**WE TRUST POLARIS VES OIL IN THE EXTREME 2,000 MILE (3,219 KM) IRON DOG EVENT BECAUSE AMONG ALL THE ISSUES WE FACE, IT'S ONE LESS THING WE HAVE TO WORRY ABOUT.**

- MIKE MORGAN, IRON DOG RACER

## POLARIS® BLUE

Synthetic Blend engine oil specially formulated for excellent protection and performance in all 2-cycle injector or pre-mix non-VES applications.

### OUR FORMULATION

- Synthetic Blend formula
- High lubricity
- Proprietary corrosion additive package

### YOUR ADVANTAGE

- Excellent cold flow for easier starting down to -70°F (-40° C)
- Prevents rust and corrosion, ring sticking and plug fouling
- Lower total cost of ownership including extending the life of the engine

1 L  
502571

25 L  
502501

200 L  
502504

4 L  
502495

60 L  
502503

**1000+**  
**HOURS**

DYNO TESTING

**64,374**  
**KILOMETERS**

FIELD TESTING



# ENGINEERED TO MAXIMIZE THE LIFE OF YOUR RIDE

All Polaris® fluids—from anti-freeze to brake fluid—are developed for your vehicle. Trust the only fluids perfectly engineered for your needs.



## CARBON CLEAN

Polaris® Carbon Clean prevents ethanol corrosion, stabilizes fuel, and cleans carburetor jets and fuel injector nozzles, deposits on piston and rings, intake systems, and combustion chambers. Antioxidants preserve fuel and prevent fuel system gumming.

125 ml | 502528



## DOT 4 BRAKE FLUID

Polaris® DOT 4 Brake Fluid is designed for use in Polaris® hydraulic brakes. Superior high-temp characteristics plus anti-corrosion additives extend the life of brake system components.

250 ml | 502526



## SYNTHETIC CHAINCASE LUBE

Unlike typical gear case oils, SCL's unique viscosity range allows instant flow and film protection in extreme cold or high heat environments.

1L | 502560  
25L | 502561  
201L | 502562



## OIL

Polaris® Blue, VES, and VES Extreme 2-cycle oils are tested to perform, and are the only oils developed specifically for your Polaris® snowmobile engine. Exclusive anti-wear additives protect engine parts with extra rust and corrosion protection.

2-Cycle oils Part numbers. See previous page.



## ANTI-FREEZE

Polaris® Extended Life Anti-Freeze contains organic acid technologies to prevent corrosion on metal components, eliminate scaling, and maximize cooling system performance.

1L | 502566  
25L | 502567  
206L | 502568



## ALL-SEASON GREASE

Polaris® All-Season Grease is designed to maintain consistency across a wide range of temperatures. Engineered to protect front and rear suspension components, steering bushings, and driveline bearings.

400 gr | 502538  
185 kg | 502539



## FUEL STABILIZER

- Advanced Fuel Treatment prevents ethanol corrosion and stabilizes fuel for up to 2 years. Dual-antioxidant formula protects against gum and varnish for easy starting

125 ml | 502519



## SHOCK OIL

1L | 502518

# CLEAN YOUR VEHICLE



## CLEAN

### ALL-PURPOSE CLEANER

- Professional grade, non-streak and biodegradable universal cleaner for the whole sled

500 ml | 502533



## SHINE

### INSTANT SHINE & DETAILER

- Quick and protective cleaning for a sparkling clean result. Polaris Instant Shine and Detailer does not need additional water! Ideal for plastics, glass, varnishes, metals as well as windscreens and visors

500 ml | 502546



*Oil and cleaners featured are for EU distribution only. For other availability, contact your local dealer.*



# LIFT IT SECURELY. LIFT IT SAFELY.

Trying to raise a snowmobile on makeshift stands is never a good idea. The Polaris® Vehicle Lift secures the snowmobile safely, eliminating the risk of the sled toppling while it's being worked on. Work safely, and work smarter.

## POLARIS® VEHICLE LIFT

- Get fast, easy access to the underside of your vehicle
- Manual and pneumatic operation available
- Raises vehicle up to 32" to make repairs & maintenance faster and easier
- Dual-locking safety latch for added safety
- (You also need attachment kit, see below)

1200 LBS  
2830424

Maintain your sled without adjusting the lift. You can access your belt, track, hyfax, carbides, skis, engine, and shocks. Work more efficiently and comfortably!

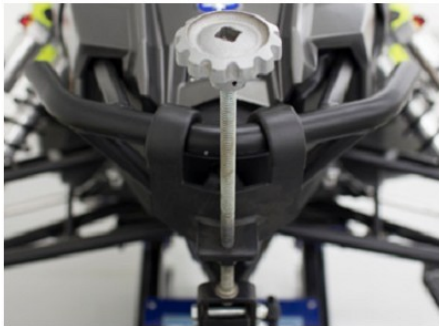
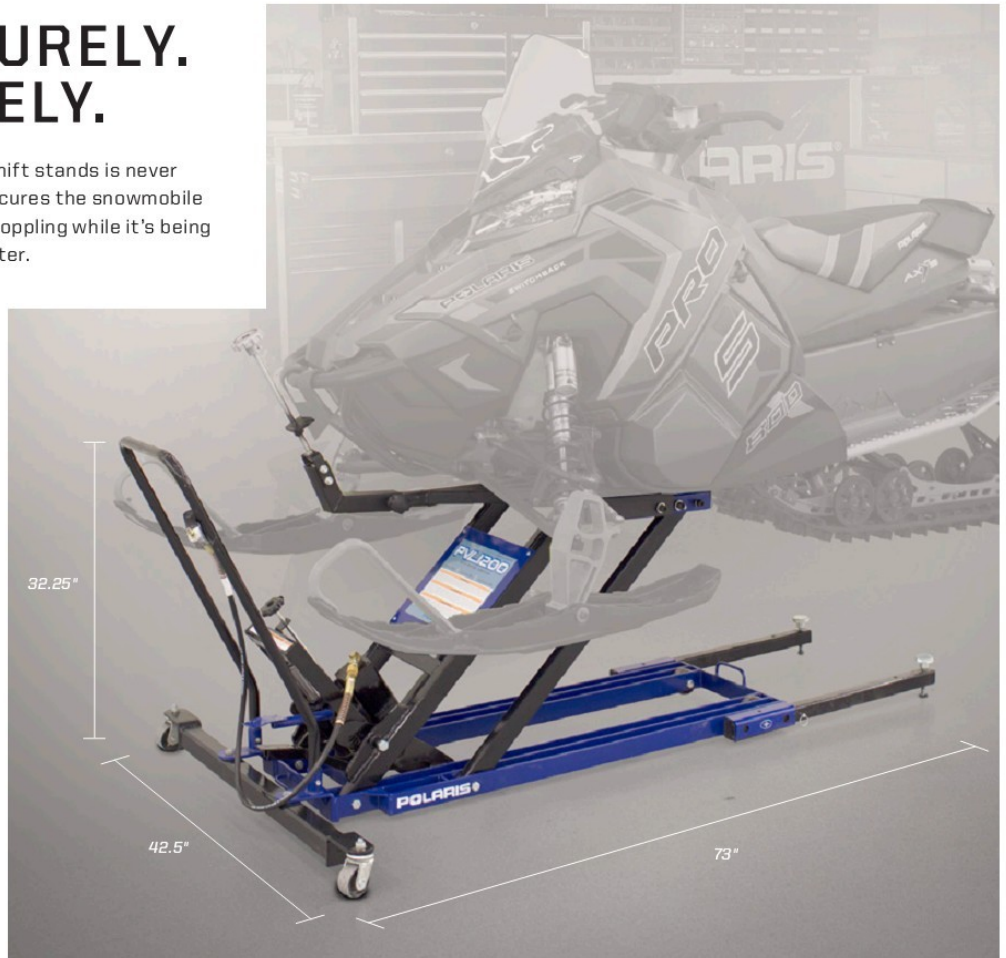

## POLARIS® VEHICLE LIFT ATTACHMENTS

ATV/Polaris Ace® | 2830427

Polaris® Snowmobile | 2830426



## POLARIS® X3 CREEPER

- Three positions: flat, 45-degree angle, or seated work stool
- Helps you perform any repair with ease
- Stay dry and warm away from cold, wet concrete floors
- Easily stores away when not in use

Black | 2830429



## POLARIS® HEAVY DUTY SCRUBBER WIPES-90CT

2830441



## POLARIS® SHOP TOWELS

2830440 | 64 ct

2830402 | 200 ct

2830403 | 200 ct refill



## POLARIS® MAGNETIC PARTS TRAY

Silver | 2830432



## POLARIS® 84 CM TELESCOPIC MAGNET

Black | 2830435



## POLARIS® 30.5 CM HI- TORQUE RATCHETING DRIVER

Black/Blue | 2830434



## POLARIS® LED POCKET FLASHLIGHT

Black | 2830436

OVER  
**100,000**  
PARTS  
AVAILABLE!



**POLARIS ENGINEERED SERVICE PARTS DELIVER UNMATCHED PERFORMANCE AND FIT FOR YOUR SLED.**

Our engineers at Polaris® create snowmobile parts that push the limits of weight versus strength. We build our parts to feel lighter without sacrificing strength and durability. But over time, your sled will eventually need some service. When we're engineering our high-performance components, we keep serviceability in mind. From a quick clutch inspection to a ski alignment, we build our products as a system, so that anyone with the right tools and training can easily maintain their vehicle from their own garage—and get back on the trails where your snowmobile belongs.



**SHOP FOR SERVICE PARTS AT YOUR POLARIS DEALER.**





**SKAFFA POLARISKORTET REDAN IDAG!**

DELBETALNING UPP TILL

**24 MÅNADER**

PÅ TILLBEHÖR, KLÄDER, RESERVDELAR OCH SERVICE.

Läs mer och ansök på: [polarissverige.com/polariskortet](http://polarissverige.com/polariskortet)

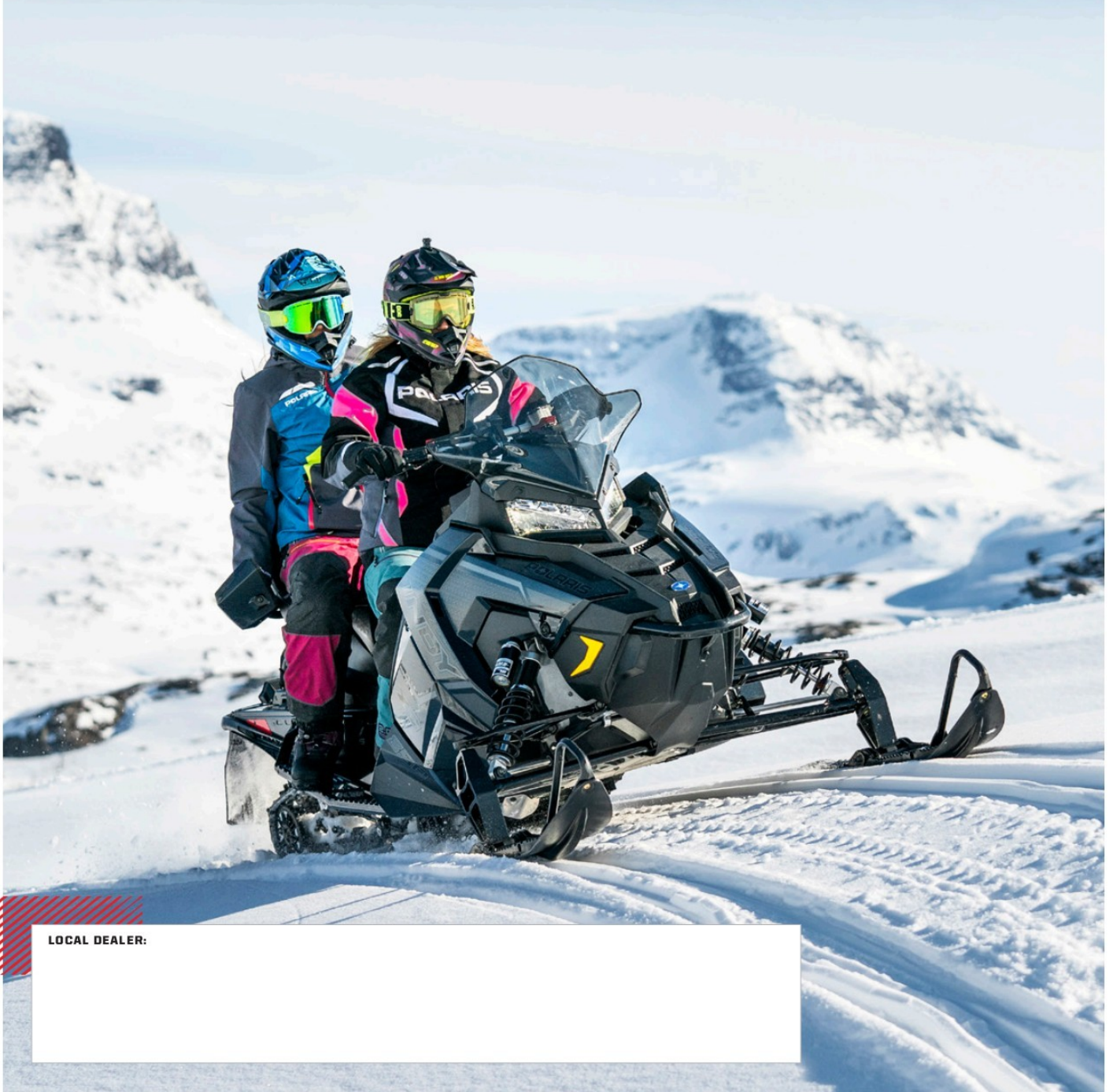

LOCAL DEALER:

[Redacted area for local dealer information]

**POLARIS SCANDINAVIA AB | [WWW.POLARISSVERIGE.COM](http://WWW.POLARISSVERIGE.COM) | [WWW.FACEBOOK.COM/POLARISSWEDEN](http://WWW.FACEBOOK.COM/POLARISSWEDEN)**

CONTACT YOUR LOCAL DEALER FOR ADDITIONAL INFORMATION!

Reservation regarding print-errors, deviation from the written content and color-deviation in the depicted material.

Polaris Scandinavia AB June 2019

#ST20205